

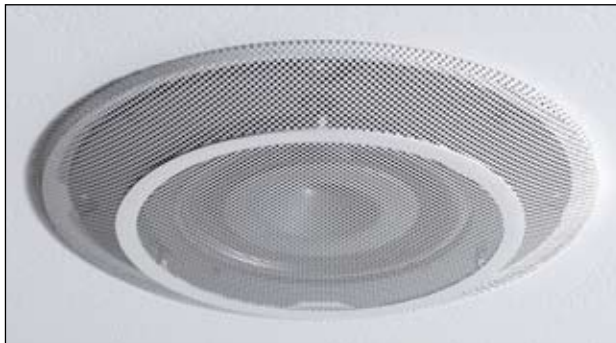

# Stella™-8C : Ceiling Mount Installation Loudspeaker

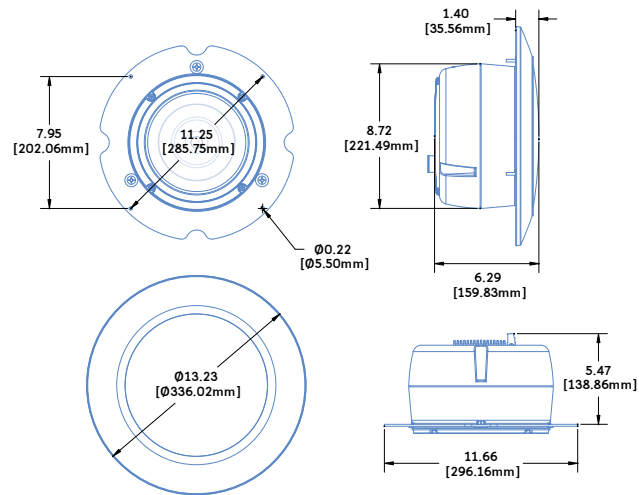

Also available in black and custom colors  
(backbox not included)



The Stella-8C ceiling mount installation loudspeaker is a self-powered loudspeaker engineered primarily for use in Meyer Sound’s Constellation electroacoustic architecture. Housed in an aluminum die cast enclosure with a heatsink on the back, the Stella-8C can be flush-mounted in ceilings and walls with standard backboxes for 8-inch drivers (with a minimum depth of 6.5 inches).

The Stella-8C delivers similar acoustical performance as the Stella-4 and Stella-4C loudspeakers, but with expanded output capability and wider coverage. The unit’s 8-inch coaxial cone and 0.75-inch tweeter transducers can produce a maximum peak SPL of 117 dB at one meter over a wide frequency range of 100 Hz to 22 kHz. The Stella-8C contains amplification and signal processing onboard and exhibits the same low distortion, high intelligibility, and flat frequency and phase

response for which Meyer Sound products are known. As a self-powered loudspeaker, the Stella-8C offers simplified installation for the multichannel output of Constellation systems or other installation applications.

Balanced audio and DC power are fed to the Stella-8C from a 5-pin Phoenix connector on its rear panel. Meyer Sound’s patented Iso-Input™ transformer-isolated differential input circuit yields a high common mode signal rejection ratio (CMRR). Powering the unit from a unipolar 12 to 18 V DC external power source reduces induced noise significantly, while the use of a low voltage supply eliminates the need for wiring conduits.

The required method for delivering balanced audio and DC power to the Stella-8C is with the Stella-188 external power supply. The single-space 19-inch rack unit can accommodate up to

eight Stella-8Cs (one per channel output). The Stella-188 receives eight channels of balanced audio from its 25-pin D-sub connector and routes the audio, along with 18 V of DC power, to its 5-pin Phoenix output connectors for greater wiring convenience. Cable runs to the Stella-8C of up to 150 feet are possible with just 1 dB of loss in peak SPL using 18 AWG wire.

The use of composite multiconductor cables (such as Belden® 1502R) allows a single cable to carry both audio and DC power from the Stella-188 to the Stella-8C. The Stella-8C amplifier and signal processing circuits are designed to tolerate voltage drops of up to 30 percent, thereby accommodating light-gauge cables and long cable runs. Internal energy storage circuits minimize the system’s peak-to-average current demands, ensuring efficient use of the Stella-188’s 18 V DC output.

## PRELIMINARY SPECIFICATIONS

|                                       |  |
|---------------------------------------|--|
| <b>Operating Frequency Range</b>      | 100 Hz – 22 kHz  |
| <b>Frequency Response, Free Field</b> | 115 Hz – 20 kHz ±4 dB  |
| <b>Maximum Peak SPL</b>               | 117 dB (free field, measured with music and referred to 1 meter)   |
| <b>Phase Response</b>                 | 2 kHz – 18 kHz ±45°  |
| <b>Coverage</b>                       | 100°   |
| <b>Transducers</b>                    | One 8" coaxial cone driver, one 0.75" metal dome tweeter   |
| <b>Voltage Requirement</b>            | 12–18 V DC   |
| <b>Audio/Power Connector</b>          | Single 5-pin Phoenix (3 pins for audio, 2 pins for DC power)   |
| <b>Input Impedance</b>                | 20 kΩ balanced internal isolation (Iso-Input) transformer  |
| <b>Nominal Input Sensitivity</b>      | +6 dBV (2.0 V rms, 2.8 V peak) continuous average is typically the onset of limiting for noise and music   |
| <b>Input Level</b>                    | Audio source must be capable of producing +15 dBV (5.6 V rms, 8.0 V peak) into 600 Ω to produce maximum peak SPL over the operating bandwidth of the loudspeaker |
| <b>Current Draw</b>                   | 3.1 A average; 6.3 A peak  |
| <b>Noise Floor</b>                    | <20 dB A weighted  |
| <b>Dimensions</b>                     | 11.66" (front) x 5.47" (depth without grille)<br>296.16 mm (front) x 138.86 mm (depth without grille)  |
| <b>Weight</b>                         | 9.0 lbs (4.1 kg) without backbox   |

*Stella-188 external power supply required*

Stella-8C – 04.162.004.01 A

Copyright © 2007  
Meyer Sound Laboratories Inc.  
All rights reserved

**MEYER SOUND LABORATORIES INC.**  
2832 San Pablo Avenue  
Berkeley, CA 94702

T: +1 510 486.1166  
F: +1 510 486.8356

techsupport@meyersound.com  
www.meyersound.com