

The Meyer Sound P-2 is an active signal processor designed for use with Meyer Sound UPM-2 loudspeakers. It occupies a single 1¾ inch rack space. The functions of the P-2 are:

- Loudspeaker frequency response alignment
- SpeakerSense™ driver protection
- Loudspeaker driver excursion protection
- Low-frequency cut for system equalization

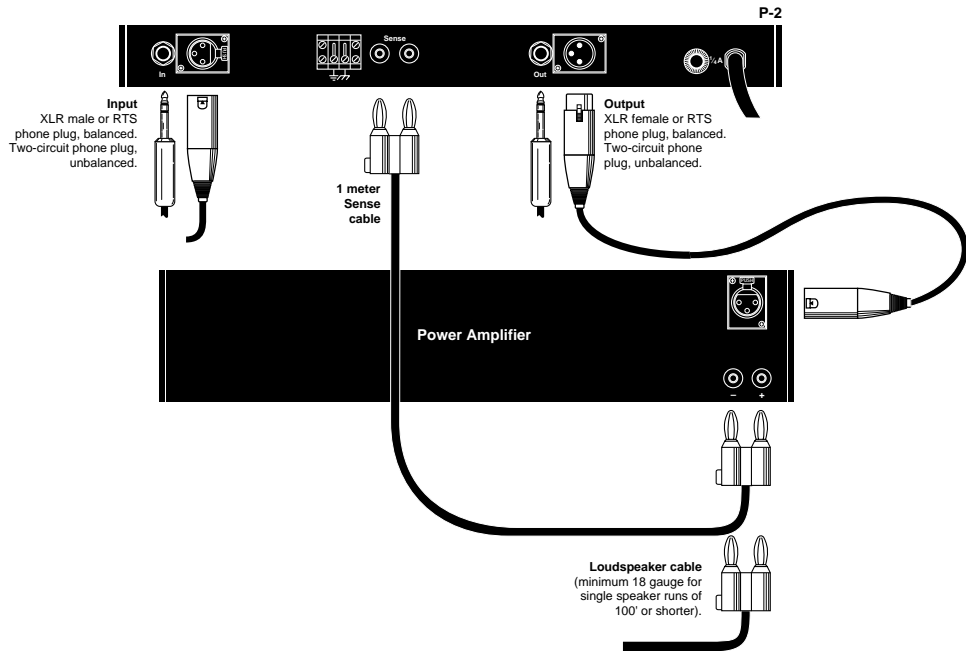

Connections

The P-2 operates at line level and is intended to be the final component in the signal chain before the power amplifier. Connections between the P-2 and the power amplifier should be made according to the diagram above.

1. Signal inputs to the P-2 may be either balanced or unbalanced. For best signal-to-noise ratio, use balanced connections operating at +4 dBu nominal. The P-2 will accept peak input levels up to +26 dBu. Connector polarity is as follows:

	XLR	Phone
Signal +	pin 3	tip
Signal -	pin 2	ring
Common	pin 1	sleeve

2. SpeakerSense connections are made from the output of the amplifier to the P-2 Sense input. The connection **must** be made for the P-2 protection circuitry to operate. Polarity of this connection does not matter.

3. Signal output from the P-2 is active balanced at +4 dBu nominal operating level, and AC coupled with pin 1 tied to AC/chassis ground through a 200 ohm resistance. The maximum output level is +26 dBu balanced (+20 dBu unbalanced). The Output drives the UPM-2 power amplifier. Connector polarity is the same as the input connector.

4. Connections between the power amplifier output and the UPM-2 should be made in accordance with the UPM-2's **Operating Instructions**. These connections **must** be verified for correct polarity.

Note. The grounding strap located next to the signal input controls the connection between signal ground (circuit ground) and earth ground (chassis ground). With the strap removed, signal ground is disconnected from earth. This feature may be used to control ground loops in the system.

Operation

Once all the connections have been made and verified, the system is ready to operate.

- Switch on AC power to the P-2, then to the power amplifier.

- Set the power amplifier voltage gain to between 20 dB and 30 dB.

- Advance the P-2's Level control to set the system sensitivity.

Lo Cut Switch

The **Lo Cut** switch on the P-2 front panel introduces a 6 dB/octave high-pass filter at 160 Hz. The filter may be used to reduce low-

frequency emphasis caused by corner placement of the UPM-2 loudspeaker or to compensate for cardioid microphone proximity effects.



**SpeakerSense™
Driver Protection**

Through the rear-panel **Sense** connection back to the P-2 from the power amplifier, the **SpeakerSense** circuitry continually monitors the voltage across the UPM-2 drivers. If the amplifier output exceeds the safe operating limits of the drivers, an RMS limiter and low-frequency excursion limiter are automatically activated, holding down the P-2 output level. Until the onset of overload, the SpeakerSense circuitry has no effect on the sound of the system. The operation of the protection circuitry is indicated by two front-panel LEDs.

Sense Indicator — This signal presence indicator verifies that the Sense connection has been made between the P-2 and the power amplifier. It will be lit whenever a signal is present, or flicker at low levels.

Limit Indicator — This indicator will come on when the limiter is activated. Moderate flashing of this indicator is acceptable; if it is on continuously, the drive level should be reduced. The RMS limiter has an attack time of 100 msec and will **not** affect program peaks.

Limiter Operation

To verify RMS limiter operation in the field:

- Disconnect the loudspeakers, leaving the P-2 and amplifier connected as described on the first page of these instructions.
- If the amplifier requires a load, use a resistive load sufficient to dissipate the full power of the amplifier.
- Turn on the P-2 and the amplifier.
- Supply an input to the P-2, preferably a sine wave oscillator set to 1 kHz. If you do not have an oscillator, a Compact Disc player or cassette tape machine with full-range program material may be used.
- Advance the P-2 **Attn** control until you see the Limit indicator come on. Since the indicator will light **only** if the limiter actually functions, it provides a positive indication of limiter operation.

Specifications

Input Type	Balanced (active), 47k ohms
Output Type	Push-pull (active), 200 ohms source impedance
Maximum Input/Output Level	
Unbalanced	>+20 dBu
Balanced	>+26 dBu
Hum and Noise ¹	<-90 dBV
Dynamic Range ²	>105 dB
Sense Input	10K ohms true differential
Driver Protection Circuitry	RMS and LF Excursion Limiters
Indicators	
Sense	Green LED
Limit	Red LED
Power	Green LED
Controls	Level control, AC on/off switch, Lo Cut switch
Connectors	
Balanced Input/Output	3-pin XLR (A-3) and 1/4" phone jacks
Sense Input	Banana jacks
Power	120/240V AC, 50/60 Hz (internally switchable)
Physical Dimensions	19" W x 1 3/4" H x 7 3/4" D Standard rack mount
Weight	7 lbs. (3.2 kg)

Note 1:

"A" weighted.

Note 2:

Noise floor to maximum output.