

Meyer Sound

© Meyer Sound Laboratories, 1993.

MSPN 05.102.217.01 A

SIM System II Reference Manual

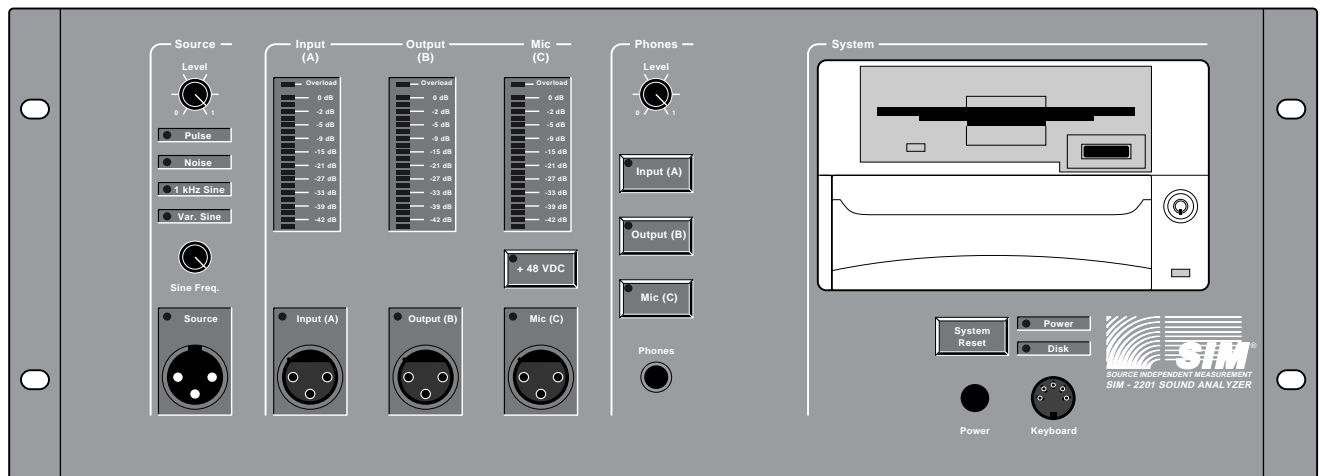

SIM[®] System II Reference Manual

This manual reflects Release 5.1 of the system software.



Copyright © 1993 by Meyer Sound. All rights reserved. No part of this work covered by the copyrights hereon may be reproduced or copied in any form or by any means — graphic, electronic, or mechanical, including photocopying, recording, taping, or information retrieval systems — without prior written permission of the publisher:

Meyer Sound
2832 San Pablo Avenue
Berkeley, CA 94702
Phone (510) 486-1166
Fax (510) 486-8356

First Printing: April 1993

SIM® is a registered trademark of Meyer Sound.

Contents

Introduction	3	2.3.13 Memory Tracking	34
About This Reference Manual	3	Room/Eq	34
Physical Model	3	Branch Compare	34
Section 1 — Hardware	4	Additional notes for v. 2.3 Stereo and Multi-channel	34
1.1 Front Panel Audio Hardware	4	2.3.14 Related Commands and Shortcut Keys	34
1.2 Front Panel System Hardware	5	F5 (Freeze)	34
1.3 Rear Panel Audio Hardware	6	F6 (Clear)	34
1.4 Rear Panel System Hardware	7	F10 (Live/Memory Display Toggle)	34
Section 2 — Software	8	2.4 Setup Menu	35
2.0 Boot-up of the SIM System II Software	8	2.4.1 Reference channel	36
2.1 Status Panels	12	2.4.2 Measurement channel	36
2.1.1 Data Status Area	12	2.4.3 Names	37
2.1.2 Cursor status area	13	2.4.4 Speakers	38
2.1.3 System status area	14	2.4.5 Microphones	38
2.1.4 Input status area	15	2.4.6 Branches	38
2.1.5 Overall status area	16	Branch Naming	38
2.2 Measure Menu	16	Editing Addresses and Channels	39
2.2.1 Spectrum	16	Exiting the Branch Setup Panel	39
2.2.2 Delay finder	19	2.4.7 Delay	39
Internal Delay Time	20	2.4.8 trace Offset	39
Delay finder axes	20	2.4.9 saVe	40
Delay finder Amplitude threshold	20	2.4.10 Load	40
Time/Bandwidth Selection	20	2.4.11 dElete	41
Setting the Internal Delay Time	20	2.4.12 New	41
Notes regarding the Delay finder and measuring loudspeakers ...	20	2.4.13 Default Setup	41
Pre-Eq External Delays	23	2.5 Util Menu	42
Characterizing Reflections	23	2.5.1 Vertical Scale	42
Polarity Checking	23	2.5.2 Smoothing	43
2.2.3 Frequency response	24	2.5.3 Master Gain	43
Frequency response Cursor	25	Setting Master Gain	44
2.2.4 fEedback finder	27	Shortcut Keys	44
2.3 Data Menu	30	2.5.4 Gain: A, B, or C (v. 2.0 Lab only)	44
2.3.1 Store	30	2.5.5 Position (Mic Gain — v. 2.3 Stereo and Multi-channel only) ..	44
2.3.2 Recall	31	2.5.6 Autoset Delay (F3)	44
2.3.3 saVe	31	2.5.7 Amplitude threshold (v. 2.0 Lab only)	44
2.3.4 Load	31	2.5.8 Coherence threshold (v. 2.0 Lab only)	45
Shortcut Keys	31	2.5.9 Zoom	46
2.3.5 Disk menu	32	2.6 Averages	47
Notes on naming data files	32	2.6.1 The Averaging Menu	47
2.3.6 dElete	32	2.6.2 Average Menu Selections	48
2.3.7 Save All	32	2.7 Cursor	49
2.3.8 Load All	32	2.8 Generator	50
2.3.9 save Ascii	32	2.8.1 Off (F1)	50
2.3.10 Panel	32	2.8.2 Noise	50
2.3.11 Notepad	33	2.8.3 Pulse	50
2.3.12 Viewing Memory Data	34	2.8.4 1 kHz Sine	50

2.8.5 Variable sine	50	4.3.2 IDE Disk controller	76
2.9 Help	51	4.3.3 I/O Card	77
2.9.1 Setup	51	4.3.4 DSP Card	77
2.9.2 Keys	51	4.3.5 Motherboard	77
2.9.3 Names	51	4.3.6 SIMMs (Single In-line Memory Modules.)	77
2.9.4 Info	51	4.3.7 Power Supply	77
2.9.5 Procedure	51	4.3.8 DC Converter PCB	78
Section 3 — Stereo and Multi-channel Menus	52	4.3.9 Floppy drive	78
3.1 View Menu	52	4.3.10 Hard Drive Receptacle	78
3.1.1 Single Channel Spectrum and Feedback Find	52	4.3.11 Hard drive Cartridge	78
3.1.2 Dual Channel Delay Finder and Frequency response	52	4.4 Rear panel service	78
3.2 Branch Menu	53	4.5 Front panel service	78
Shortcut keys	54	4.6 Factory service required	78
3.3 Procedure Menu	55	Section 5 — Appendices	79
3.3.1 Pretest	56	A. Connection Diagrams	79
3.3.2 Single System	56	B. Cable Pinout Charts	83
3.3.3 External Delay	57	C. ISO™ Input (Channels A and B)	85
Definitions	57	D. ASCII Data File Example	86
Post-Eq Delay Lines	57	E. Shortcut Keys	88
Pre-Eq Delay Lines	60	v. 2.0 Lab	88
3.3.4 Lobe Study	64	v. 2.3 Stereo, v. 2.3 Multi-channel	89
3.3.5 Combined Systems	64		
3.3.6 Mic Eq	64		
Foot (Mouse) Mics	65		
3.3.7 mlc Compare (v. 2.3 Multi-channel only)	67		
Microphone evaluation	68		
Acoustic response measurements without speakers	68		
3.3.8 Show	68		
3.3.9 pOst process	69		
3.3.10 Quit	69		
3.3.11 Speaker Menu	69		
Select	70		
Enable	70		
Select and Enable	71		
Summary	71		
Section 4: Service	73		
4.1 Non-fatal failures	73		
4.2 SIM 2201 BIOS Setup	74		
Accessing BIOS Setup Program	74		
Navigating and Selecting Values	74		
Standard CMOS Setup Values	74		
Advanced CMOS Setup Values	74		
Advanced Chipset Setup Values	75		
Auto Configuration with BIOS Defaults	75		
Auto Configuration with Power-On Defaults	75		
4.3 User-Serviceable	76		
4.3.1 SVGA	76		

Introduction

About This Reference Manual

The SIM Reference Manual is intended to serve as a reference document for the users of SIM System II. The manual is divided into five sections. The main body of the manual is devoted to the **v. 2.0 Lab** configuration. Wherever differences occur between this and the **v. 2.3 Stereo** and **v. 2.3 Multi-channel** versions, the version-related aspects are specified.

Section 1: Hardware — This section describes the front and rear panel connectors, knobs and switches.

Section 2: Software — This section describes the system software, beginning with the boot-up. The remainder of Section 2 is devoted to a discussion of each of the Main menus and their sub parts. The order of the Main Menu choices in this manual follows the menu bar from left to right for the **v. 2.0 Lab** configuration. There are three Main Menus that appear exclusively in **v. 2.3 Stereo** and **v. 2.3 Multi-channel**, and these are covered in Section 3. The order of the Sub-Menu choices typically follows their position in the pull-down menu, from top to bottom.

Section 3: Stereo and Multi-channel Menus — This section describes the main menu items that are specific to **v. 2.3 Stereo** and **v. 2.3 Multi-channel**.

Section 4: Service — This section describes service of the SIM-2201 Sound Analyzer.

Appendix — Connection information, connector pinouts and Ascii data file sample.

Physical Model

SIM System II is designed for not only characterizing, but also electronically correcting, acoustical systems. Its architecture and nomenclature follow a physical model consisting of a loudspeaker in a room (object of measurement) with a measurement microphone, and a parametric equalizer (correction network) connected in series with the input signal. The excitation is assumed to be neither totally random nor predictable, though known test signals such as noise or stepped sine waves may be used.

The instrument's three input ports are connected respectively to the correction network input (A), the network output (B), and the measurement microphone (C). Three different transfer functions may be computed: Room + Speaker (the unequalized response of the speaker in the room); Eq (the equalizer response); and Result (the equalized speaker system response).

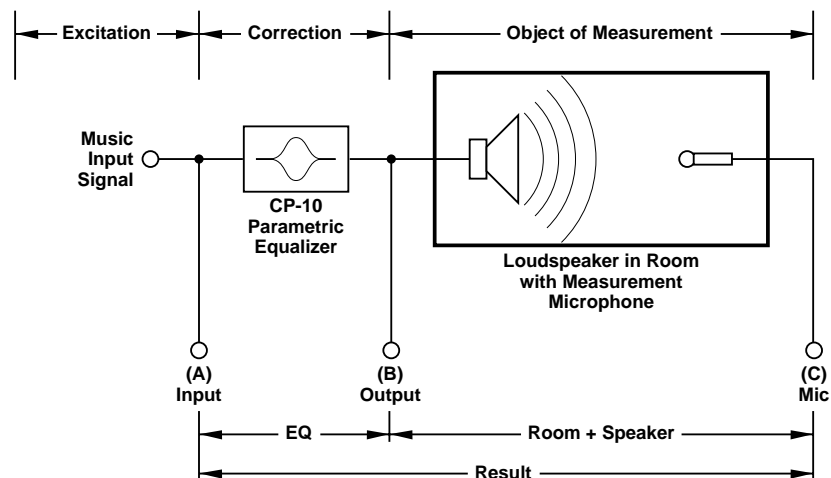

Figure 1 — SIM System II Physical Model

Section 1 — Hardware

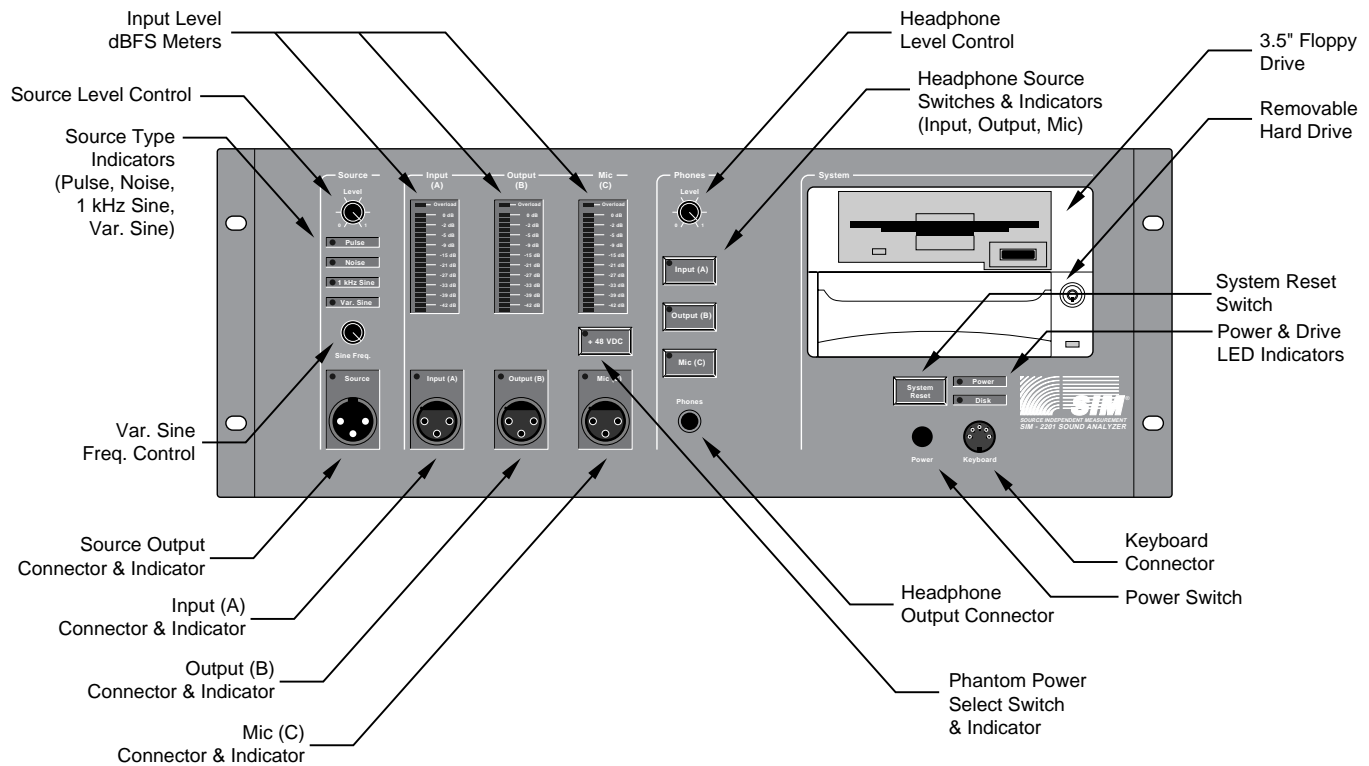

Figure 2 — SIM-2201 Front Panel Controls and Indicators

1.1 Front Panel Audio Hardware

1.1.1 Source Level — A rotary level control for the source output.

1.1.2 Source Type — The source signal type is selected from the Generator Menu, and the selected source is indicated by a green LED.

Noise — Pink random noise

Pulse — A pink filtered Pulse at an average rate of 1.1 Hz. The interval ranges from .9 to 1.3 Hz

1 kHz Sine — Sine wave for distortion measurement and setting gains

Variable Sine — For manually operated sine wave sweeps

1.1.3 Sine Freq. — A rotary control for variable sine frequency. The ranges are:

Low 16 Hz - 1 kHz

High 500 Hz - 22 kHz

Range is selected from the Generator Menu.

1.1.4 Source Output — The source output is a male XLR-type (A3) with 300 ohm balanced source impedance. A green LED located next to the connector is illuminated whenever the source output is active.

1.1.5 Headphone Level — A rotary level control for the headphone output.

1.1.6 Headphone Source Switches — Three membrane switches select the measurement bus channel to be monitored: Eq Input (A), Eq Output (B) or Microphone (C).

1.1.7 Headphone Output — A three-circuit 1/4" phone jack for connecting headphones to monitor the three measurement signal buses. Connect only to headphones equipped with a three-circuit (stereo) jack. Minimum impedance is 32 ohms, and monitoring is monophonic only.

1.1.8 Level Meters — Three LED bar meters indicate the signal headroom below full-scale digital. The meters indicate the peak level as a ratio (in dB) to the maximum allowed by the A/D converters. The meters are post gain control, and therefore always indicate the headroom of the converters. Their decay time is 500 ms.

The meters show the level at the Channels A, B and C respectively. The signal path is version dependent:

<u>Version</u>	<u>Ch. A meter</u>	<u>Ch. B meter</u>	<u>Ch. C meter</u>
v. 2.0 Lab	Input (A)	Output (B)	Mic (C)
v. 2.3 Stereo	Eq In Bus	Eq Out Bus	Mic (C)
v. 2.3 Multi-channel	Eq In Bus	Eq Out Bus	Mic Bus

1.1.9 Signal Inputs — Three female XLR-type (A3) connectors located on the front panel provide direct access to the three measurement points. Each channel has an LED that illuminates when the channel is active.

Input (A) and Output (B) are both signal inputs; the nomenclature refers to the input and output, respectively, of the device under test. The maximum signal level for these inputs is 28 volts peak. They are wired pin 3 hot, and incorporate Meyer Sound's ISO™ Input circuitry (see Appendix D), providing full transformer isolation and accommodating any connection configuration with no change in gain.

The Mic (C) input is wired pin 2 hot to conform with the accepted standard for measurement microphones, and can be supplied with Phantom power (48 VDC) via a front-panel membrane switch.

v. 2.0 Lab — Input (A), Output (B) and Mic (C) are selectable.

v. 2.3 Stereo — Mic (C) is active. Input (A) and Output (B) are patched through the Stereo Snake.

v. 2.3 Multi-channel — No front-panel input connections are active except in the special case of Procedure: Mic Compare, where the front panel Mic Input is used. Otherwise, all connections are made through the SIM-2403 Interface Network.

1.1.10 Phantom Power (+48 Volt) Select Switch — A membrane switch that toggles the phantom power to the Mic (C) input connector. A red LED located next to the switch is illuminated when the phantom power is enabled.

1.2 Front Panel System Hardware

1.2.1 Power Switch — A pushbutton to switch power to the system.

1.2.2 Reset Switch — A membrane switch that resets the system.

1.2.3 Power LED — This green LED lights when the system is powered.

1.2.4 Drive LED — This LED lights when the hard drive is reading or writing.

1.2.5 Floppy Drive — The drive accepts standard 3.5" 1.44 Mbyte floppy disks.

1.2.6 Removable Hard Drive — This removable cartridge contains a 120 Mbyte IDE auto-parking hard drive. The cartridge may be removed when the system is to be shipped. **The cartridge should not be removed or inserted while the system is powered up.**

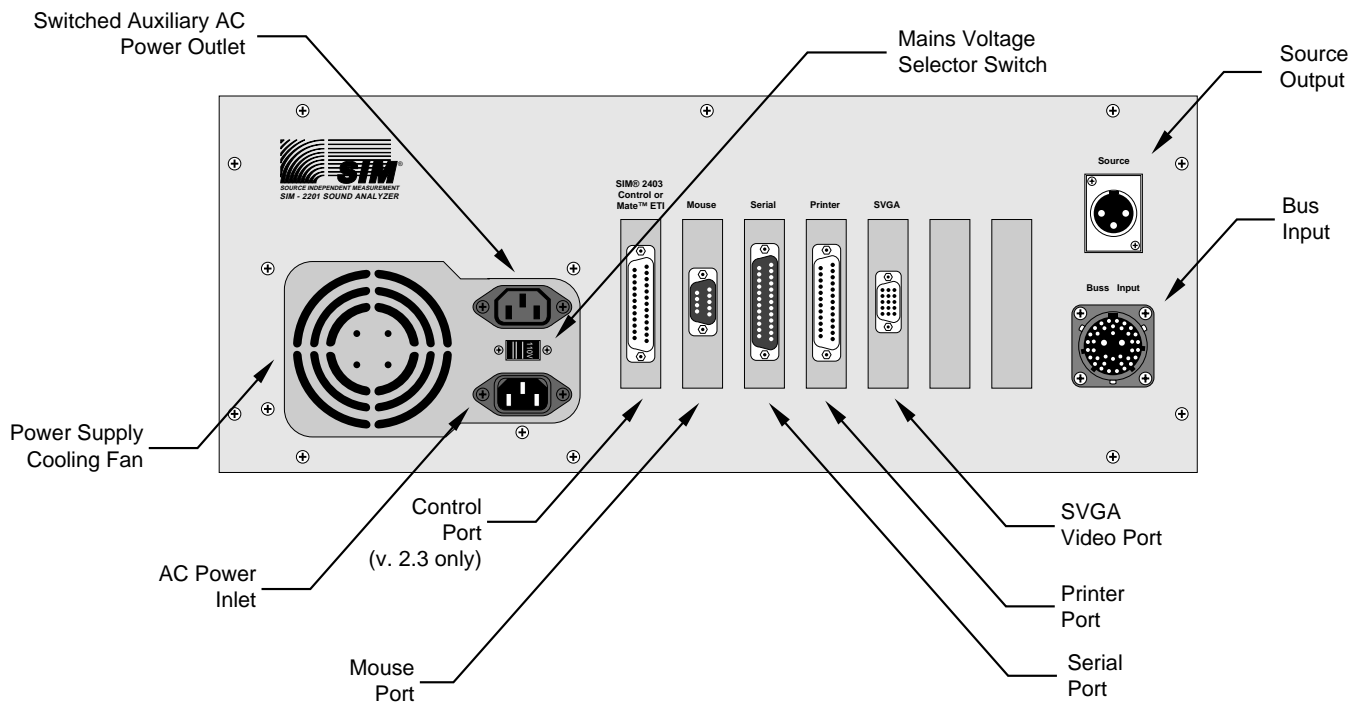

Figure 3 — SIM-2201 Rear Panel Controls and Connectors

1.3 Rear Panel Audio Hardware

1.3.1 Bus Input — A 39 pin Multi-connector which carries audio signals to the SIM-2201 Sound Analyzer.

v. 2.0 Lab: Not used

v. 2.3 Stereo: The Stereo Snake is connected here.

v. 2.3 Multi-channel: The Bus Output Cable from the SIM-2403 Interface Network is connected here.

1.3.2 Source Output — A male XLR with 300 ohm balanced source impedance. A green LED located next to the Source Output front panel connector is illuminated whenever the source output is active. The front and rear connectors are hard-wired in parallel.

1.4 Rear Panel System Hardware

1.4.1 Power Inlet — Takes universal IEC power cable.

1.4.1 Mains Voltage Selector — The power supply is designed to run over a wide range of line voltages. The chart below shows the specified range for the two selectable settings.

<u>AC Line Voltage</u>	<u>Switch Setting</u>
90-125 VAC 50/60 Hz	115
200-250 VAC 50/60 Hz	230

1.4.2 Power Outlet — Switching courtesy outlet for video monitor.

1.4.3 SVGA — 15 pin D-shell connector carrying video output to monitor.

Caution: The video cable must be plugged so that the 15 pin end is connected to the SIM 2201. Attempting to connect a 9-pin VGA cable at the SVGA output may cause pins to bend.

Note: For a detailed description of the SVGA Video Card, please refer to the SVGA Video Card user's manual.

1.4.4 Serial — RS 232 Serial port (Com 2).

1.4.5 Printer — Parallel port for interface with printers (see Section 2.5.10 **Util: Print**).

1.4.6 Mouse — Serial PC Mouse port (Com 1).

Note: For a detailed description of the Serial, Printer and Mouse ports please refer to the PTI-217 Multi I/O Card user's manual.

v. 2.3 Multi-channel

1.4.7 Control — D25 connector to control SIM-2403 Interface Network.

Note: For a detailed description of the I/O Driver PCB please refer to the Keithley Metrabyte P10-24 user's manual.

Section 2 — Software

2.0 Boot-up of the SIM System II Software

2.0.1 Installing and Updating SIM Software On the Hard Drive

The hard drive is pre-formatted with the original SIM System II Software installed. Subsequent updates will arrive on floppy disk with installation instructions. The new version is installed onto the hard disk using the Utilities function. The floppies should be saved as a backup.

2.0.2 Boot-up from the Hard Drive

- 1) Insert the removable hard drive cartridge. **Do not slam!**
- 2) Remove any floppy disk from the floppy drive.
- 3) Turn the SIM-2201 Sound Analyzer on. After checking the A: floppy drive, the SIM-2201 Sound Analyzer will look to the C: drive to boot the program.
- 4) The SIM System II Program will automatically load and run.

2.0.3 Boot-up from Floppy Disk

- 1) Choose one of the three program disks available:
 - v. 2.0 Lab
 - v. 2.3 Stereo
 - v. 2.3 Multi-channel
- 2) Insert the SIM System II Program disk for that version into the floppy drive.
- 3) If it is desired to save data on the hard disk, then insert the hard drive cartridge.

The floppy drive is configured as the A: drive and therefore the system will attempt to boot from this drive first. The hard drive is configured as the C: drive. (If the program has already been installed on the hard drive, there is no need to boot from floppy disk.)

- 4) Turn the SIM-2201 Sound Analyzer on.
- 5) The SIM System II Software will automatically load and run.

<p>Note: The boot-up time from floppy is dependent upon whether or not the hard drive is installed: Boot-up from floppy with hard disk installed — 1 minute Boot-up from floppy w/o hard disk installed — 2 minutes.</p>

<p>Note: The Video monitor must be connected before the system is powered up. If not, the display will display black and white only. To correct this, the system must be reset.</p>
--

2.0.4 Boot-up of Software other than SIM

- 1) Insert a bootable disk into the floppy drive, **or** insert a separate portable hard drive with the desired program.
- 2) Turn the SIM-2201 Sound Analyzer on.

Caution: Bootable floppies other than the SIM Software may corrupt the SIM Software on the hard disk. If other programs are used, it is advised that the SIM Software hard disk not be inserted.

When you wish to return to the SIM System II Program, power down and follow the boot-up Procedure as outlined in Section 2.0.2.

2.0.5 Beginning the Program

The function keys select the various SIM Software versions and Utilities.

F1 2.0 Lab — For single or dual channel measurements of individual components or networks. All input connections are made on the analyzer front panel. This program is used for stand-alone measurements and research.

F2 2.3 Stereo — This program is used for analysis and alignment of recording studios or stereo sound reinforcement systems. It uses the Stereo Snake connected to the rear panel of the SIM-2201 Sound Analyzer for access to the Input (A) and Output (B) channels. A single microphone is patched into the front panel Microphone input (C).

F3 2.3 Multi-channel — This program is used for analysis and alignment of complex sound reinforcement systems. It uses the SIM-2403 Interface Network plugged into the rear panel of the SIM-2201 Sound Analyzer to access eight equalizer input and output channels and eight microphones. The system can be expanded to include up to eight SIM-2403 Interface Networks for a maximum of sixty-four equalizer channels and microphones.

v. 2.3 Stereo and v. 2.3 Multi-channel utilize three DSP engines for parallel processing to achieve a three-fold improvement in data acquisition speed over v. 2.0 Lab.

F9 Utilities — This program is used for computer-related utility functions. A sub-menu will appear with the following selections:

F1 Install — This is used for installing new releases of the SIM Software from floppy disks onto the hard disk. Follow the instructions to install each of the programs.

F2 Format disk — Follow the instructions to format blank 1.44 Mbyte high density 3.5 inch floppies.

F3 Select a SIM Printer — This utility contains a library of 128 printer drivers, including both color and black and white printers. Follow the instructions to install the printer driver for your printer. The selected printer will appear as the "Other" printer in the Util: Print menu. Many of the drivers have not been tested, and Meyer Sound cannot guarantee compatibility with all printer models.

2.0.6 Signing In

When the program is finished loading, you will be prompted to update the system time and date. Press <Enter> to accept the present settings, or enter new settings and press <Enter>.

The screen will then display a series of sign-in prompts. Here, you will enter labels that will be saved with the data Notepad and will be stored along with data that you save to disk in v. 2.3.

2.0.7 The SIM System II Menus

The SIM Software user interface is both logical and intuitive. At the top of the display is the Menu Bar, comprising the main system menus. These are selected by typing the first letter (highlighted in red) of each menu. When the letter is typed, the menu will open to display the available sub-menu choices.

Throughout this manual, menu choices are shown in **bold face** type. The highlighted red character in the program is denoted with an underline. The main menu choice always appears first followed by a colon, followed by the sub-menu choices.

Example — **Measure: Delay finder** refers to the Main menu item “Measure” which is selected by the letter “M”. Its sub-menu item “Delay finder” is selected by the letter “D” and selected with <Enter>. The command consists of:

M D <Enter>

Once a Main menu is open, adjacent menus may be selected with the left/right arrow keys. The sub-menus can be selected by using either the highlighted letters or the up/down arrow keys.

The presently selected sub-menu is always shown with a dark gray background. To select the current sub-menu, simply press the <Enter> key. You may also cancel without changing any settings by pressing <Esc> at any time. For more information, use the Help Menu Keys selection.

Procedure	Measure	View	Branch	Data	Setup	Util	Averages	Generator	Help
-----------	---------	------	--------	------	-------	------	----------	-----------	------

No menus have been selected

Procedure	Measure	View	Branch	Data	Setup	Util	Averages	Generator	Help
	Spectrum								
	Delay finder								
	Frequency response								
	fEedback finder								

The Measure menu has been selected using the “M” key. The current selection, Frequency response, is highlighted.

Procedure	Measure	View	Branch	Data	Setup	Util	Averages	Generator	Help
	Spectrum			Time:	BW:				
	Delay finder			± 70 ms	10k				
	Frequency response			± 140 ms	5k				
	fEedback finder			± 280 ms	2k5				
				± 560 ms	1k2				

The Delay finder menu has been selected using the “D” key. Pressing <Enter> to accept the selection has caused the Delay Time sub-menu to appear. The current selection, ±70 ms, is highlighted.

Figure 4 — Pull-Down Menus

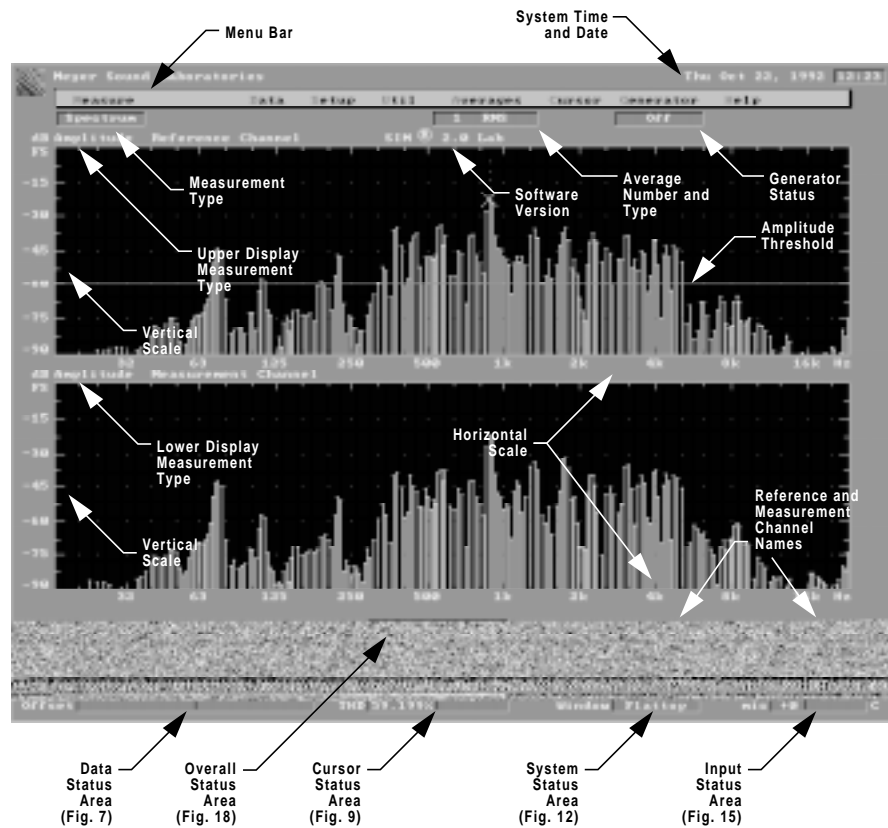

Figure 5 — v. 2.0 Lab Main Screen

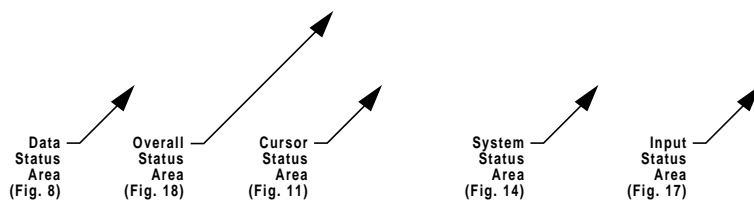

Figure 6 — v. 2.3 Multi-Channel Main Screen

2.1 Status Panels

2.1.1 Data Status Area

The lower left area of the screen displays information about the traces, in two columns. The left column refers to the primary traces (bright colors) and the right column refers to the secondary traces (muted colors).

	Data	
Traces	Live	Memory
Data		
Group	2 Lab Data	1 Lab Data
Notes	On Axis	+15 vert
Offset	+4.00 dB	+4.00 dB

Figure 7 — v. 2.0 Lab Data Status Area

Traces	Live = Incoming measurement data Memory = Data from Recall Buffer
Group	Left column = Data Store Group number and data type Right column = Data Recall Group number and data type
Note	Left column = 1st 10 characters of Notepad for primary traces Right column = 1st 10 characters of Notepad for secondary traces
Offset	Frequency response Amplitude offset in dB

	Data	
Traces	Live	Memory
Branch	1 Left	1 Left
Group	2 Comb Sys	1 Single Sys
Notes	After Re-EQ	Initial EQ
Spkrs	12_____	1_____
Offset	0.00 dB	0.00 dB

Figure 8 — v. 2.3 Multi-Channel Data Status Area

Traces	Live = Incoming measurement data Memory = Data from Recall Buffer Memory A = Data from Recall A Buffer (Post-Process only) Memory B= Data from Recall B Buffer (Post-Process only)
Group	Left column = Data Store Group number and data type (Procedure) Right column = Data Recall Group number and data type (Procedure)
Note	Left column = 1st 10 characters of Notepad for primary traces Right column = 1st 10 characters of Notepad for secondary traces
Spkr	Left column = Number of speakers on for primary data Right column = Number of speakers on for secondary data
Offset	Left Column = Frequency response Amplitude offset in dB for primary data Right Column = Frequency response Amplitude offset in dB for secondary data

2.1.2 Cursor status area

The lower left center box refers to the Cursor trace.

		Cursor		
Data	live	3610		Hz
Type	Meas	-8.7		dBV
THD	.002			

Figure 9 — Measure Spectrum Cursor Status Area

Data	Live = Incoming measurement data (only)
Type	v. 2.0 Lab: Ref (Generator or Input A), Meas (Output B or Mic C) v. 2.3 Stereo and v. 2.3 Multi-channel: Eq in, Eq out, Mic v. 2.3 Multi-channel: Ref mic, MeasMic (Mic Compare only)
THD	Total harmonic distortion in percent at the Cursor position
Hz	Frequency of Cursor location (X axis)
dBV	Amplitude in dBV at the Cursor

		Cursor		
Data	Live	44.60		ms
Type	Result	-0.7		Ampl
Delay	73.70			

Figure 10 — Measure Delay Finder Cursor Status Area

Data	Live = Incoming measurement data (only)
Type	v. 2.0 Lab: IFT (Inverse Fourier Transform) v. 2.3 Stereo and v. 2.3 Multi-channel: Room+speaker, Eq or Result
Delay	Delay offset between Reference channel and present Cursor position (in ms)
ms	Delay offset between Internal Delay Time and present Cursor position (in ms)
Ampl	Amplitude ratio at the Cursor

		Cursor		
Data	Live	15200		Hz
Type	Result	-6.3		dB
Mean S/N	4.0 dB			

Figure 11 — Measure Frequency response Cursor Status Area

Data	Live = Incoming measurement data Memory = Data from recall Buffer
Type	v. 2.0 Lab: Ampl (amplitude), Phase, S/N (signal-to noise + distortion) or Coher (Coherence) v. 2.3 Stereo and v. 2.3 Multi-channel: Room+speaker, Result, Eq, 1/Eq
Mean S/N	Mean Signal-to-Noise (or Coherence) over entire bandwidth
Hz	Frequency at the Cursor
dB	Amplitude in dB at the Cursor

2.1.3 System status area

The lower right center box displays global instrument parameters.

Delay	76.06 ms
Thresh	-60 dB
BW	1/6 oct
Window	Flattop

Figure 12 — Measure Spectrum System Status Area

Delay	Internal Delay Time in ms
Thresh	Amplitude threshold referenced to full scale in dB
B/W	Effective bandwidth of passband filter
Window	Window function applied to time record

Delay	76.06 ms
Thresh	-40 dB
BW	10 kHz
Window	Half Hann

Figure 13 — Measure Delay Finder Status Area

Delay	Internal Delay Time in ms
Thresh	Amplitude threshold value referenced to full scale in dB
B/W	Effective frequency bandwidth (-3dB point)
Window	Window function. The Half Hann Window is applied to the Frequency response data prior to the IFT.

Delay	76.06 ms
Thresh	60% Coh
BW	1/24 oct
Window	Hann

Figure 14 — Measure Frequency response Status Area

Delay	Internal Delay Time in ms
Thresh	Coherence threshold in percent
B/W	Effective bandwidth of passband filter
Window	Window function applied to time record

2.1.4 Input status area

The input status area at the lower right displays information about incoming signal levels, gains and channel names.

Reference		Measurement	
Generator		Out, B	
	Gain	dB FS	
in	+20	-3.2	A
out	+10	-6.7	B
mic	+30	- - - -	C

Figure 15 — v. 2.0 Lab Input Status Area

Reference Reference channel name (Generator or A)
Measurement Measurement channel name (B or C)
Gain A, B, C Gain (-20 to + 50 dB) of each channel
dB FS Signal levels of each channel referenced to full scale in dB

EQ		SPEAKER	
chn		Name	
1		HD-2	
	Gain	dB FS	
in	+20	-3.2	
out	+20	-3.6	
mic	+30	-6.7	

Figure 16 — v. 2.3 Stereo Input Status Area

Speaker Channel number and name for speaker
Gain In, Out, Mic Gain (-20 to + 50 dB) of each channel
dB FS Signal levels of each channel referenced to full scale in dB

EQ		SPEAKER		MICROPHONE				
adr	chn	Name		adr	chn	Name		
0	1	MSL-10		0	7	Balc 1		
						Gain	dB FS	
						in	+20	-3.2
						out	+20	-3.6
						mic	+30	-6.7

Figure 17 — v. 2.3 Multi-Channel Input Status Area

Eq Address and Channel number of Eq
Speaker Name for speaker
Microphone Address, channel number and name for microphone
Gain In, Out, Mic Gain (-20 to + 50 dB) of each channel
dB FS Signal levels of each channel referenced to full scale in dB

2.1.5 Overall status area

The Overall Status Area at the lower center displays information about the overall system status.

Acquiring Data

Figure 18 — Overall Status Area

Acquiring Data	Processing incoming data
Pause	A menu is open, suspending processing
Input disabled	Space bar has disabled the input — press it again to continue
Data rejected	Overload of the measurement inputs — data are rejected
Data <threshold	All signals are under the Amplitude threshold
Writing	Writing to disk
Reading	Reading from disk
Searching	Searching for data files on disk
Printing	Printing screen
Averaging Complete	999 averages have been accumulated

2.2 Measure Menu

The Measure menu selects the type of measurement to be made.

2.2.1 Spectrum

Spectrum measurements display the single-channel amplitude response of each of the measured input channels as absolute amplitude in dB vs. frequency in Hz.

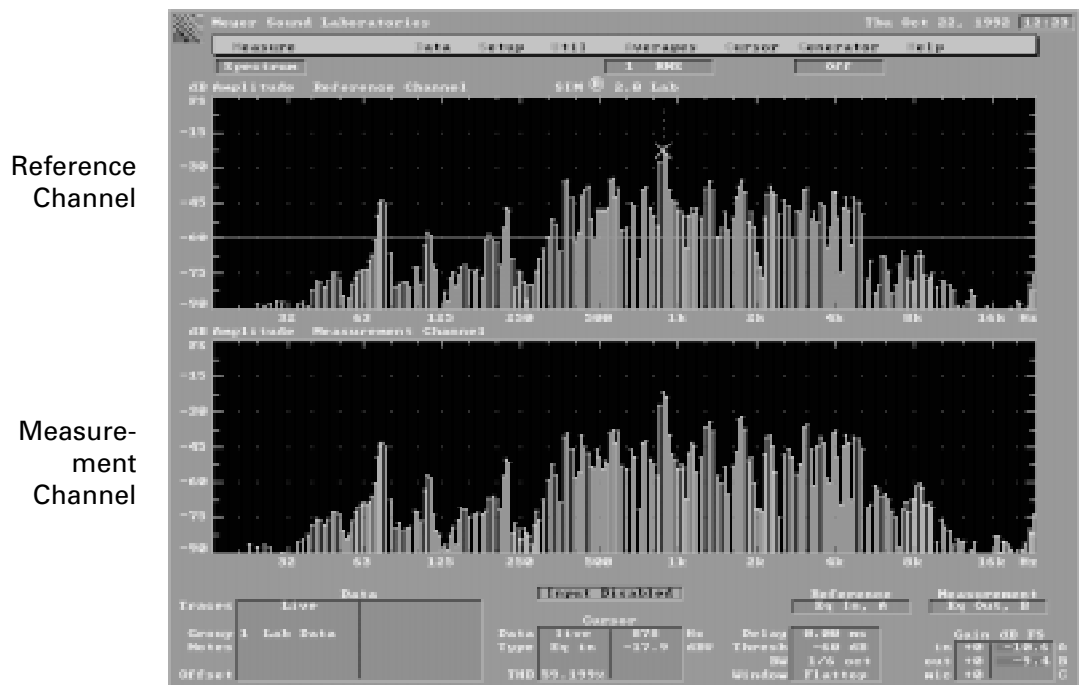

Figure 19 — v. 2.0 Lab Measure Spectrum Screen Display

Spectrum Axes

The top of the amplitude axis represents full scale digital at each frequency. The vertical scale is adjustable in dB/div. The frequency axis is a logarithmic display with 24 points/octave typical. The equivalent percentage bandwidth is fixed at 1/6th octave due to the width of the flattop window. Below 20 Hz, the axis is linear.

Spectrum Cursor

The Cursor value is read out in frequency and dBV rms. Note that the Y axis is read in dB FS (full-scale) while the Cursor value is in dBV (referenced to 1V rms). The Cursor follows the frequency of highest amplitude when peak tracking is enabled.

Spectrum Amplitude threshold

The Amplitude threshold is shown as a white trace. Only data at frequencies that exceed the Amplitude threshold will be allowed into the averager during Frequency response measurements.

Note: While the Amplitude threshold line is shown in Spectrum measurements, it has no effect upon them. It only affects measurements displayed in **Measure: Frequency response**.

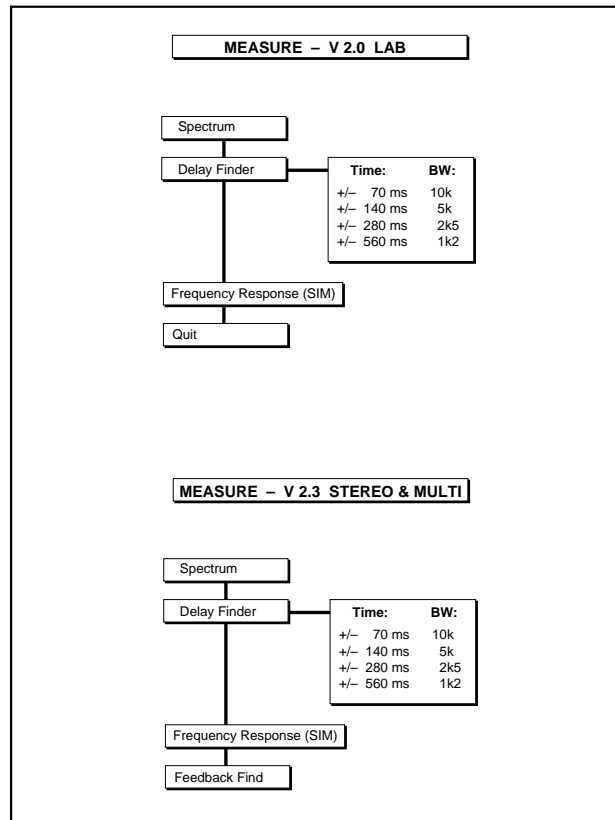

Figure 20 — Measure Menu Structure

THD

Total Harmonic Distortion (THD) is calculated at the Cursor frequency and displayed in the Cursor Status Area. To make an accurate distortion measurement, you must use a sine wave and optimize the signal-to-noise ratio of the system. The distortion measurements are computed by analyzing the signal strength of the first nine (9) harmonics above the fundamental (the Cursor position), within the 22 kHz bandwidth. THD is calculated when the fundamental frequency is below 10 kHz.

THD Example

- 1) Set the **Generator** to **1 kHz Sine** or **Var Sine**. If the Cursor does not move to the amplitude peak, set it to peak-track mode by typing **<Alt+P>**.
- 2) Adjust the Source Level Control (Front Panel) so that the amplitude peak approaches the top of the screen. The signal input meter (lower right) should read close to 0 dB. The gain should be adjusted internally with **Util: Master gain** to optimize the dynamic range of the instrument and maintain a desirable drive level. If the drive level of the fundamental is low, the readings will contain the noise products of the analyzer itself and the environment, giving an inaccurately high distortion reading.
- 3) The distortion reading is displayed in the Cursor status area. If the THD exceeds 99%, >99 will be displayed.

Window

The flattop window is chosen, as it yields the best accuracy for sine waves.

Overload Status

Data are rejected if the measurement inputs are overloaded.

Measure: Spectrum screen configuration:

v. 2.0 Lab

Screen	Type	Color	Signal Channel
Upper	Reference	White	Generator or Input (Ch A)
Lower	Measurement	Yellow	Output (Ch B)
Lower	Measurement	Orange	Mic (Ch C)

The signal channel is selected in the Setup menu

v. 2.3 Stereo and v. 2.3 Multi-channel

Screen	Color	Signal Channel
Upper	White	Eq Input
Upper	Yellow	Eq Output
Upper	Orange	Microphone
Lower	Not used	

The signal channel is selected in the View menu

2.2.2 Delay finder

The Delay finder computes and displays the amplitude response of the measured system in the time domain. Two large FFT's are performed in transfer function mode (Reference vs Measurement channel). A half Hann window is applied to the frequency data, and an inverse Fourier Transform (IFT) is then taken. This yields a calculation of the impulse response, which resembles the response that would be seen if an ideal pulse were applied to the system input and the system output were viewed on an oscilloscope. SIM System II utilizes an advanced implementation of the IFT that prevents the "phantom echoes" or "wrap-around" artifacts of conventional sampling algorithms.

The Delay finder is useful for identifying:

- time offset between the reference and measurement channels
- timing and relative level of echo structures
- time domain characteristics of filters and circuits
- polarity

Because sine waves cannot be used for time-domain measurements, the generator waveform will automatically be set to noise. The upper screen displays the relative amplitude versus time at the selected Time/Bandwidth. The lower screen displays the same data with a 10x magnified time axis.

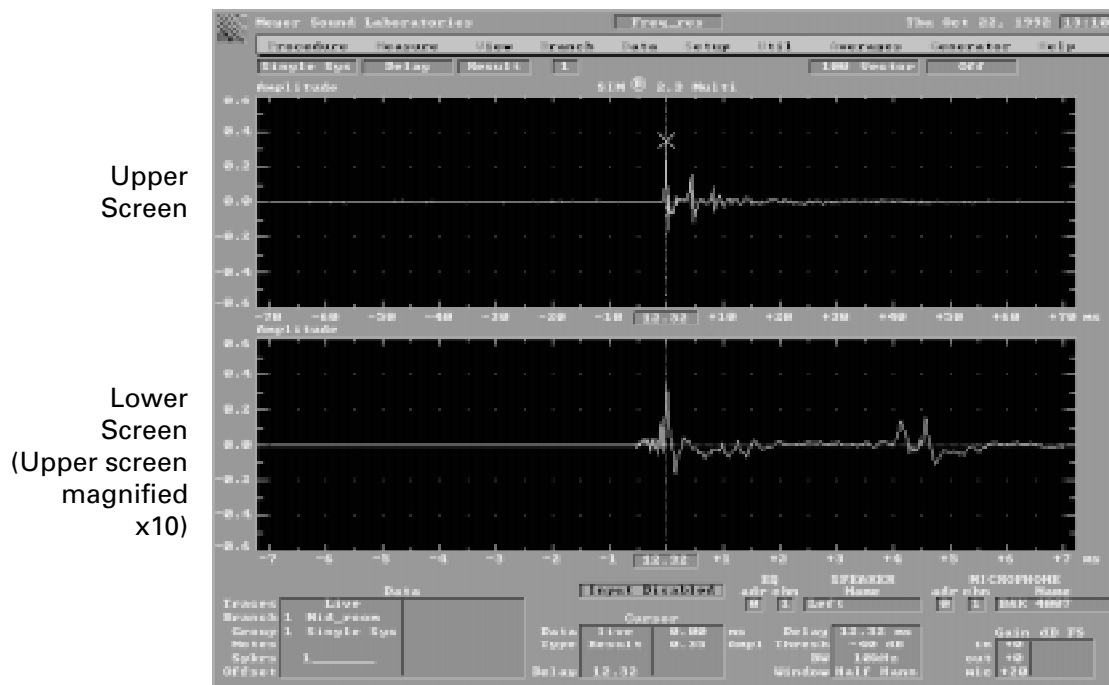

Figure 21 — Measure Delay Finder Screen Display

Note: The display in the upper screen may contain an amplitude response error, due to sampling, that varies dependent upon the data spectral density and type. This may cause the amplitude to appear lower than its actual value. The margin of error is proportional to the time offset from the center of the screen. The lower screen contains the area of the highest amplitude accuracy, $\pm .5$ dB. Therefore if accurate amplitude measurements are required, make sure that Cursor is on the trace in the lower screen.

Internal Delay Time

Before accurate Frequency response measurements can be made, you must compensate for any time delay between the Reference and Measurement channels. This is accomplished with an internal digital delay line. Delay times are selectable in increments of 20 μs , to a maximum of 983.04 ms.

Delay finder axes

The center of the horizontal axis is the present Internal Delay Time. This delay is applied to the Reference channel so that it can be made synchronous with the Measurement channel. The horizontal values to the left and right of the center represent time relative to the Internal Delay Time. When the Internal Delay Time is set such that the time delay between the channels has been compensated, the amplitude peak will be at the center of the horizontal axis.

The relative amplitude of the impulse response at a given time offset may be found by moving the Cursor to that time point and reading the value. A ratio of 2:1 between two points on the time axis indicates a difference of 6 dB.

Delay finder Amplitude threshold

The Amplitude threshold defaults to -40 dB. If the Reference channel signal level does not exceed -40 dB relative to full scale, the Delay finder will pause. The overall status window will indicate that data is below the threshold.

Time/Bandwidth Selection

The Delay finder can be configured so that any of four different time intervals can be measured. The choice of time interval is based upon the span of time you wish to view. The default setting is ± 70 ms.

Each of the Time settings has an associated Bandwidth:

Time	Bandwidth (-3 dB)	Increment
± 70 ms	10 kHz	20 μs
± 140 ms	5 kHz	40 μs
± 280 ms	2.5 kHz	80 μs
± 560 ms	1.2 kHz	160 μs

Setting the Internal Delay Time

Once the Delay finder is running, the Cursor will move to the largest amplitude on its measurement trace as shown in Figure 22a. The center of the screen will read the Internal Delay Time. Once the Cursor has stabilized, select **Util: Autoset delay** (or **F3**). This sets the Internal Delay Time to the value corresponding to the Cursor position. The new value will become the center of the screen, and the amplitude peak will move to the center of both the upper and lower screens as shown in Figure 22b.

Notes regarding the Delay finder and measuring loudspeakers

The leftmost peak in the impulse response corresponds to the arrival of the direct sound from the loudspeaker at the microphone. Echoes will appear to the right of it, because they arrive after the direct sound. If the echoes are stronger than, or equal to, the direct sound, the Cursor may lock onto the echo. In such instances, selecting **Util: Autoset delay** (or **F3**) will result in an incorrect setting of the Internal Delay Time. At any rate, it is inadvisable to attempt to align the system from such a microphone position, since the loudspeaker system may be driven into instability.

With speaker systems that lack optimum phase alignment, it may be necessary to set the Internal Delay Time to values other than the time offset of the peak with greatest amplitude. The Internal Delay Time should be set to align to

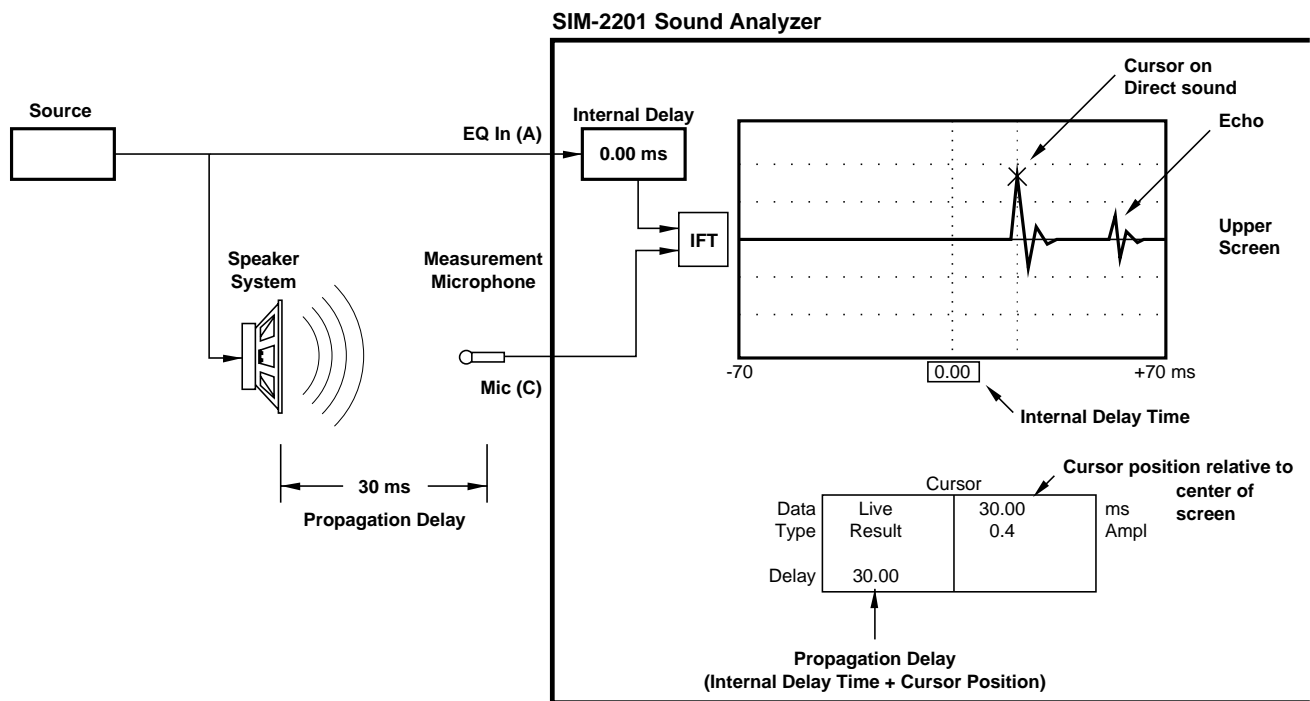

Figure 22a — Before Setting the Internal Delay: Propagation Delay Produces 30 ms Time Offset Between Reference (A) and Measurement (C) Channels

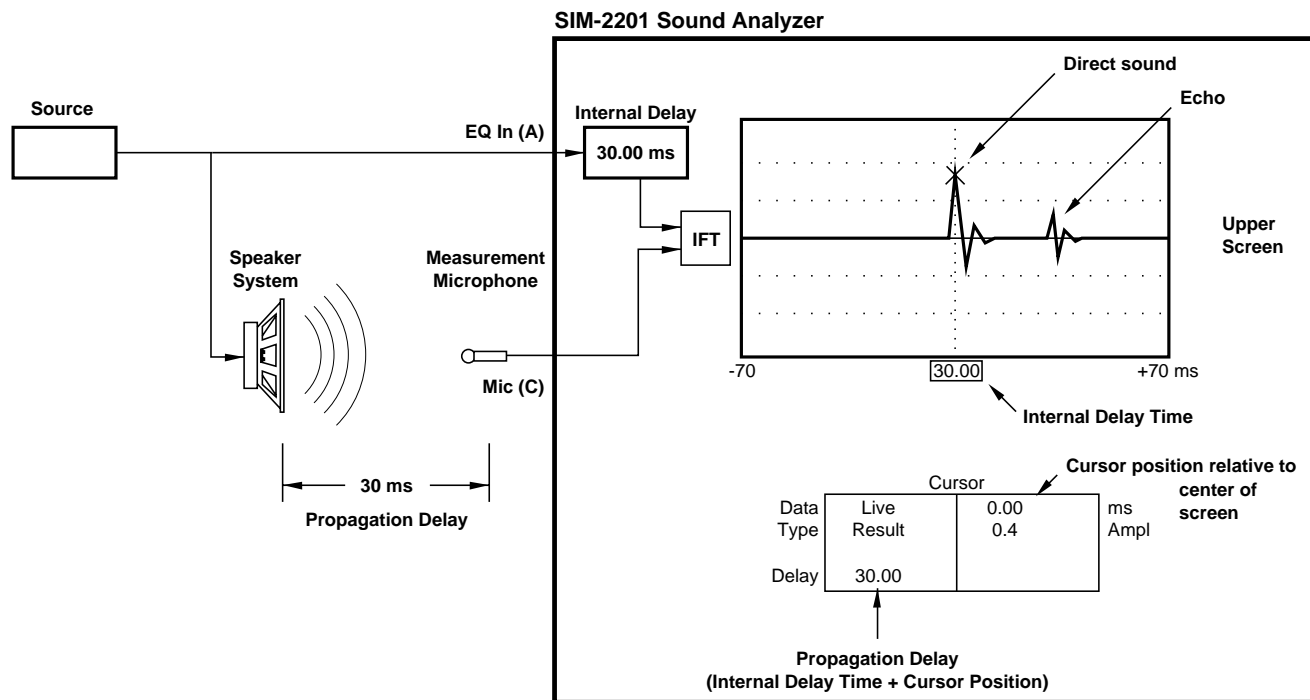

Figure 22b — After Setting the Internal Delay: Pressing F3 Sets Internal Delay to Compensate for Propagation Delay and Synchronize Channels

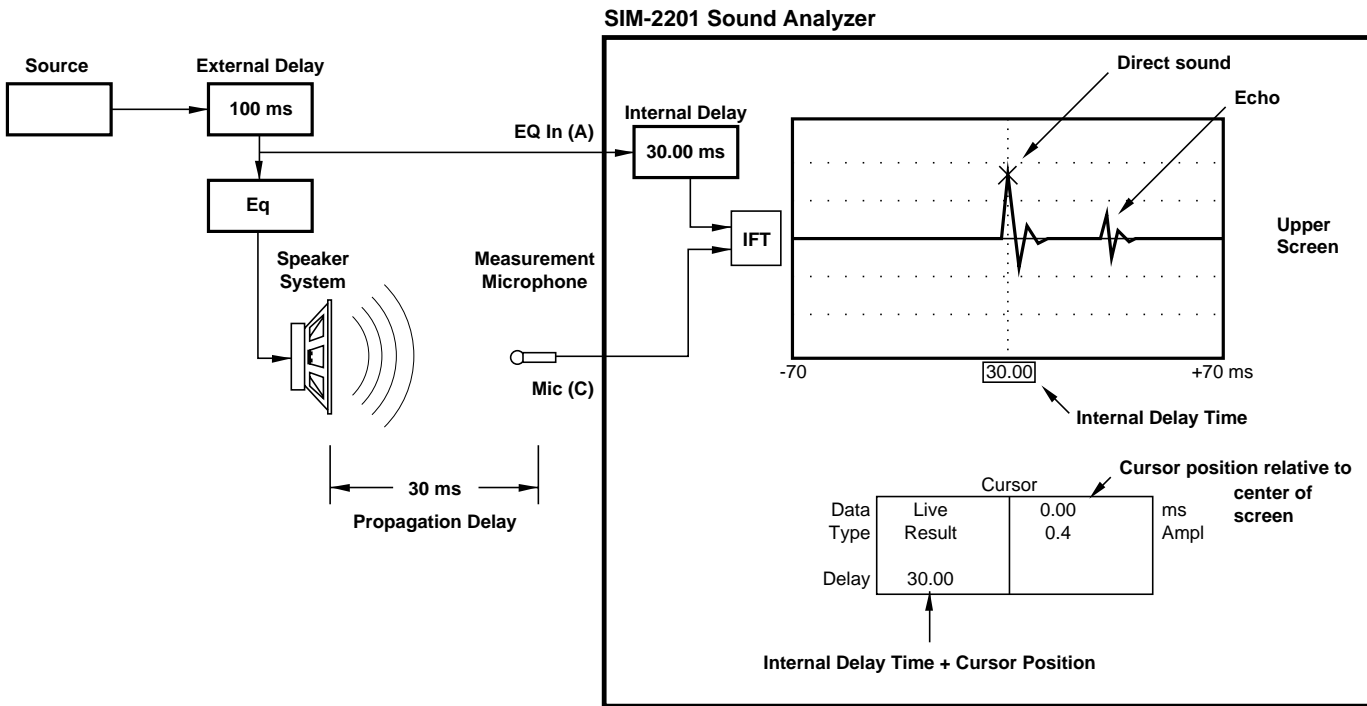

Figure 22c — Pre-Eq Delays: External Delay Does Not Affect Propagation Time Measurement

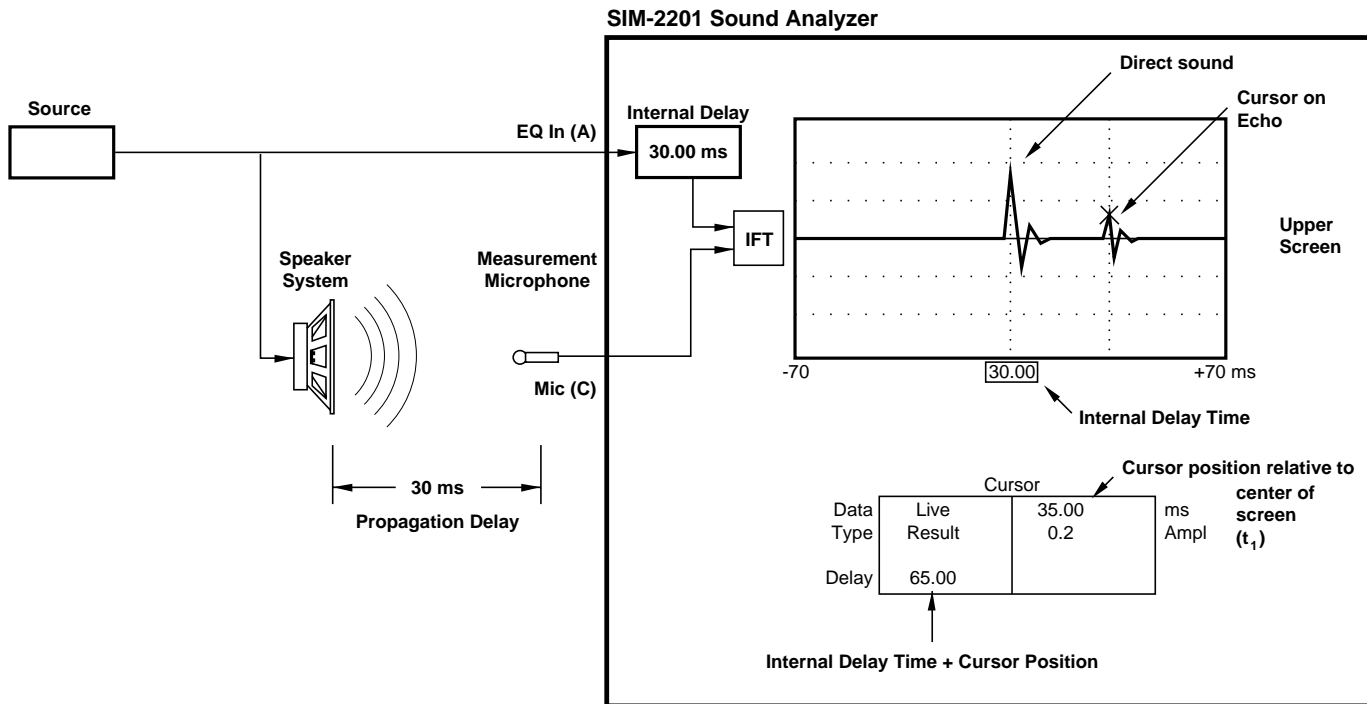

Figure 22d — Characterizing Reflections: Placing the Cursor on the Echo Provides Direct Measurement of Initial Time-Delay Gap

the highest frequency components. Always fine-tune the Internal Delay setting using the smallest Delay finder time window (10 kHz bandwidth); even small time offsets between the Reference and Measurement channels will degrade the quality of Frequency response data at high frequencies.

The Internal Delay Time does not affect signals in the system under test — only the time synchronization between the measurement channels.

Pre-Eq External Delays

As shown in Figure 22c, an external delay line that is patched before the equalizer affects both the Reference and the Measurement channel equally, as it is treated as part of the source. External delays therefore will not affect the measurement of propagation delay when the system is configured as shown in this Figure. Special Procedures are used to align delay fill systems using external delay lines (see Section 3.3.3 **External delay**).

Characterizing Reflections

The Delay finder may also be used to obtain direct measurement of the “Initial Time Delay Gap” (t_1). Recognized as a primary determinant of concert hall acoustic quality, t_1 is defined as the time delay between the arrival of the direct sound and that of the first reflection at a given location. As Figure 22d shows, simply placing the Cursor on the amplitude peak of the first reflection (after setting the Internal Delay to compensate for propagation) causes t_1 to read in the Cursor Status Area. Later arrivals (t_2 , t_3 etc.) may similarly be measured against the direct sound arrival.

Polarity Checking

The Delay finder displays the system impulse response and thus preserves polarity information. A positive-going impulse (the highest point) indicates a net non-inverting system, whereas a negative peak indicates inversion. To check polarity:

- 1) View the Delay finder response in the lower screen, which contains the full resolution needed.
- 2) Measure in the near field on axis of the speaker system whenever possible.
- 3) Verify any questionable responses by viewing the phase response (refer to Section 2.2.3 **Frequency response**).

Multiway loudspeaker systems can exhibit complex interactions in their crossover regions. It can be misleading to try to ascertain polarity information based on single drivers, since those that appear to be reversed in polarity may actually be optimized in their crossover range. Therefore, the most accurate method for measuring polarity is to view the phase response in Frequency response measurements.

Measure: Delay finder screen configuration

v. 2.0 Lab

Screen	Type	Color	Signal Channels
Upper	Time	Blue	Reference Vs Measurement
Lower	Time/10	Blue	Reference Vs Measurement

v. 2.3 Stereo and v. 2.3 Multi-channel

Screen	Type	Color	Signal Channels
Upper	Time	Blue	Result (Eq Input Vs Mic)
Lower	Time/10	Blue	Result (Eq Input Vs Mic)

The Result impulse response is the default. Room+spkr or Eq may be selected under the **View** Menu.

Colors are as follows:

Color	Type	Signal Channels
Blue	Result	Eq Input Vs Mic
White	Room+speaker	Eq Output Vs Mic
Orange	Eq	Eq Input Vs Eq Output

Note: The 1/Eq Type is not available in Delay finder.

2.2.3 Frequency response

Frequency response measurements display the difference (transfer function) between the Reference and Measurement channels in the frequency domain. The Hann Window of the time record has been chosen since it is optimized for random noise. Data are suppressed on overload of either of the two channels.

Frequency response Axes

The Frequency axis is a logarithmic display with 24 points/octave typical, and linear below 20 Hz. It can be displayed as full bandwidth or in three frequency spans (see Section **2.5.9 Util: Zoom**).

Amplitude — Amplitude in dB, vs. frequency

Phase — Phase in degrees, vs. frequency

Coherence — Coherence in percent, vs. frequency

dB S/N — Signal-to-noise ratio in dB, vs. frequency

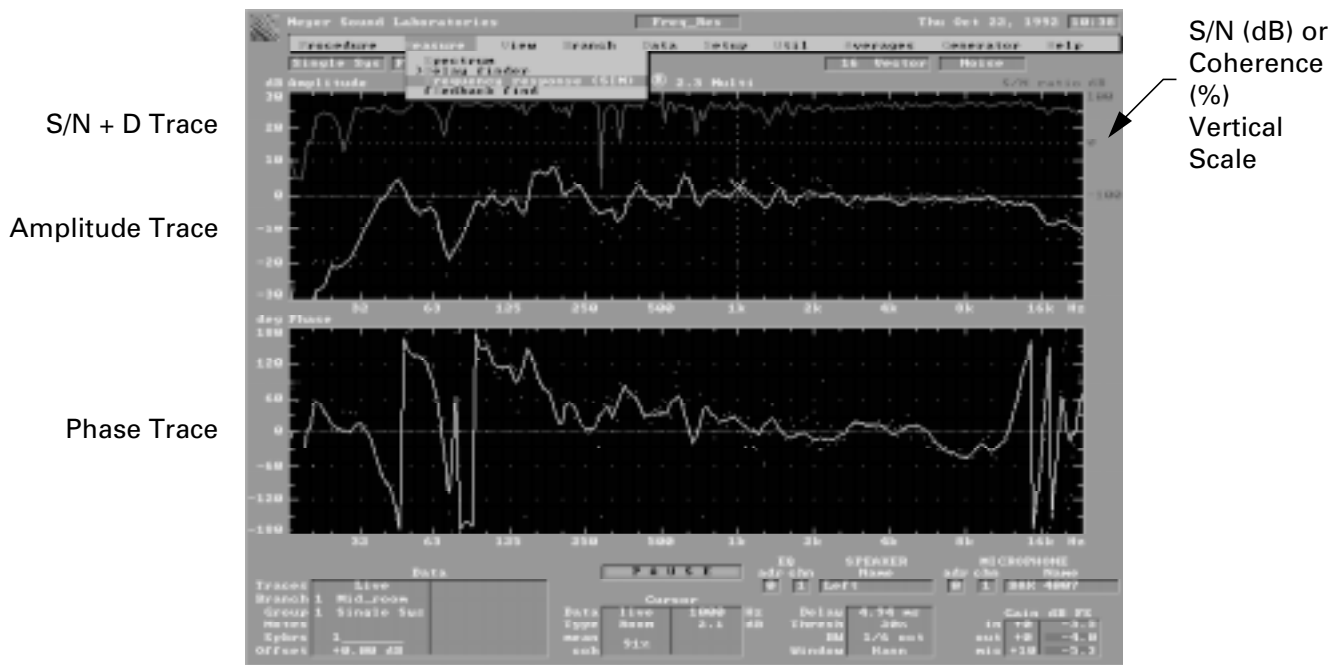

Figure 23 — Measure Frequency response Screen Display

Frequency response Cursor

The amplitude and phase Cursor values are affected by interpolation and smoothing when used. The S/N and Coherence traces are never interpolated or smoothed.

The amplitude Cursor values do not track with the **Setup: trace Offset**. The Cursor retains the actual value. Therefore when the Trace Offset function is used, the Cursor values will appear to differ from the vertical axis values by the amount of offset applied.

Frequency response Amplitude threshold

The default Amplitude threshold is -60 dB. The Frequency response display consists only of data at frequencies whose Reference channel amplitude exceeds the Amplitude threshold. If no data exceed the threshold, the system will not use any data from that time record and a prompt will appear in the main status window:

Data <threshold

Measure: Frequency response screen configuration

v. 2.0 Lab

Screen	Type	Color	Signal Channels
Upper	Amplitude (Avg.)	Blue	Reference Vs Measurement
Upper	Amplitude (Inst.)	Yellow	Reference Vs Measurement
Upper	S/N or Coherence	Red	Reference Vs Measurement
Lower	Phase (Avg.)	Blue	Reference Vs Measurement
Lower	Phase (Inst.)	Yellow	Reference Vs Measurement

v. 2.3 Stereo and v. 2.3 Multi-channel

Colors for the different Frequency response types

Color	Type	Ref. Vs Meas. ch.
Blue	Result	Eq In Vs Mic
White	Room+speaker	Eq Out Vs Mic
Orange	Eq	Eq In Vs Eq Out
Green	1/Eq	Eq In Vs Eq Out (Inverse)

v. 2.3 Stereo and v. 2.3 Multi-channel Basic View (Room+speaker, Eq or reSult)

Screen	Type	Color	Signal Channels
Upper	Amplitude(Avg.)	See Above	Room, Eq, 1/Eq or reSult
Upper	Amplitude (Inst.)	Yellow	Room, Eq, 1/Eq or reSult
Upper	S/N or Coherence	Red	Room, Eq, 1/Eq or reSult
Lower	Phase(Avg.)	See Above	Room, Eq, 1/Eq or reSult
Lower	Phase (Inst.)	Yellow	Room, Eq, 1/Eq or reSult

v. 2.3 Stereo and v. 2.3 Multi-channel Group View

Screen	Type	Color	Signal Channels
Upper	Amplitude (Avg.)	Blue	Result
Upper	Amplitude (Inst.)	Yellow	Result
Upper	S/N or Coherence	Red	Result
Lower	Amplitude (Avg.)	White	Room
Lower	Amplitude (Inst.)	Yellow	Room
Lower	S/N or Coherence	Red	Room
Lower	Amplitude (Avg.)	Orange	Eq
Lower	Amplitude (Avg.)	Green	1/Eq
Lower	Amplitude (Inst.)	Yellow	Eq or 1/Eq
Lower	S/N or Coherence	Red	Eq or 1/Eq

Bright colors are used for all primary (Live) traces
Muted colors are used for all secondary (Memory) traces

2.2.4 Feedback finder

v. 2.0 Lab — Not used

v. 2.3 Stereo, and v. 2.3 Multi-channel — Feedback finder is similar to Spectrum with the addition of a peak hold function. It is used to identify feedback frequencies when equalizing sound systems. The highest amplitude value at each frequency is held until the **Average: Restart** command is given.

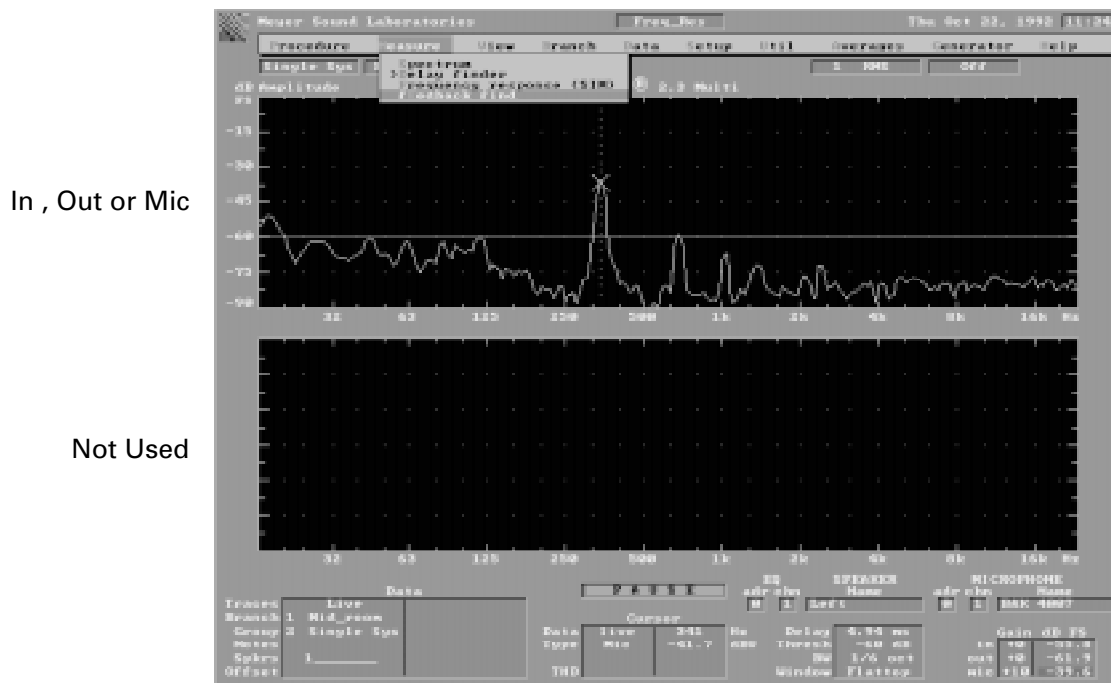

Figure 24 — Measure Feedback Find Screen Display

2.2.5 Default Mmeasure: settings

Mmeasure: Spectrum

Vertical Scale	15 dB/Div. (0 to -90 dB)
Horizontal Scale	7.6 Hz- 22,634 Hz
Amplitude threshold	-60 dB
Window	Flattop
Cursor	Peak tracking
Master Gain	0 dB
Averages	1 rms (No averaging)

Mmeasure: Delay finder

Vertical Scale	.5 Div. (± 1.5)
Horizontal Scale	± 70 msec (10 kHz)
Internal Delay Time	0 ms
Amplitude threshold	-40 dB
Window	Half Hann
Cursor	Peak tracking
Master Gain	0 dB
Averages	Accumulate vector

Mmeasure: Frequency response

Vertical Scale	10 dB/Div. (± 30 dB)
Horizontal Scale	7.6 Hz- 22,634 Hz
Amplitude threshold	-60 dB
Window	Hann
Cursor	Peak tracking
Master Gain	0 dB
Averages	4 vector

2.2.5.4 Mmeasure: feedback finder

Vertical Scale	15 dB/Div. (0 to -90 dB)
Horizontal Scale	7.6 Hz- 22,634 Hz
Amplitude threshold	-60 dB
Window	Flattop
Cursor	Peak tracking
Master Gain	0 dB
Averages	Peak hold

2.2.6 Measure Menu Reference Guide

Measure	View	Averages	Generator	Smoothing	Data	Trace Offset
Spectrum	Eq In* Eq Out Mic	1†	Off 1 k Sine Var Sine Noise Pulse	No	No	No
Delay Find	Room Eq Result*	Accum* 2 4 8 16	Off Noise Pulse	No	No	No
Freq. Resp	Room* 1/Eq Result Eq Group	Accum 2 4* 8 16	Off 1K Sine Var Sine Noise Pulse	Off (24 th) 6 th 3 rd	Store (1-8) Recall (1-8) Memory Track Save Branch Save All Load Branch Load All Delete Branch Clear	Yes
Feedback	Eq In Eq Out Mic*	Peak Hold	Off* 1 kHz Sine Var Sine Noise Pulse	No	No	No

* Default (Original Setting)

† Only available setting or not adjustable.

2.3 Data Menu

The Data Menu allows Frequency response data to be stored in memory and saved to disk. Data remain in memory as long as the SIM-2201 Sound Analyzer is powered up. Unless data are also saved to disk, they will be lost when the system is reset or power is interrupted.

The main data functions are:

Store — Stores live data in memory

Save — Saves memory data to disk.

Load — Loads data from disk to memory

Recall — Recalls data from memory to screen

The data stored include averaged amplitude and phase measurements (unsmoothed), and the Coherence (or S/N) data. When saving data to disk, the Setup must first be saved, as the Setup file also serves as a subdirectory for storing data files. Each Setup has its own data files.

2.3.1 Store

To store data, press **Data Store**. The Group menu (1-8) appears. Data may be stored to any of the eight Groups. In v. 2.3 Stereo and Multi-channel versions, each Branch has eight memory Groups.

When storing data, a Notepad pops up allowing you to enter up to three lines of text to annotate the stored data. To exit the Notepad, press <Ctrl+Enter>.

If data have been stored at this Group already, a prompt "Overwrite Y/N?" appears. Press 'Y' to overwrite data, or any other key to select a different Group.

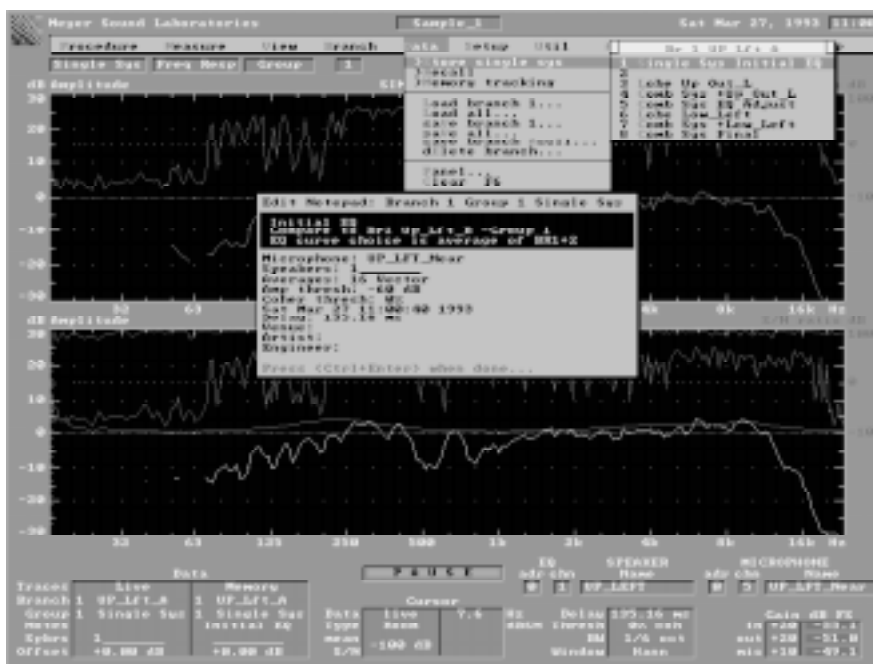

Figure 25 — Data Store Screen Display

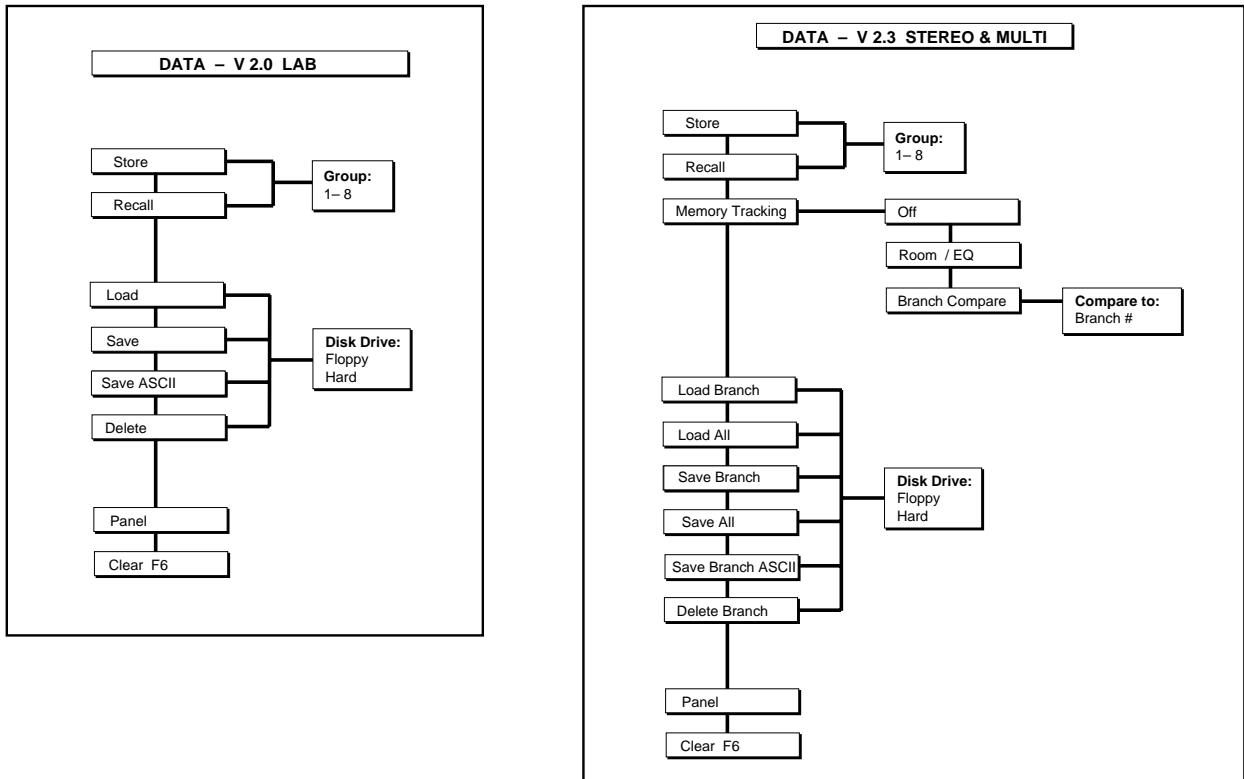

Figure 26 — Data Menu Structure

2.3.2 Recall

To recall data from memory to the screen, press **Data Recall**. The Group menu (1-8) appears. Select a Group to recall and press <Enter>. The Notepad then appears, allowing you to view and edit the text. To exit the Notepad, press <Ctrl+Enter>.

2.3.3 saVe

To save the data (all eight Groups) in memory to disk, press **Data saVe**. If the Setup has not been saved, you will be prompted for a Setup name and the Setup will be saved. Next, a prompt appears asking for the name to save the data as. Type a name and press <Enter>. The data is now saved to disk under the current Setup.

2.3.4 Load

Data loaded from disk always comes from the current Setup. To load data, press **Data Load**. A menu appears listing all the data files in the current Setup directory. Select a file and press <Enter>.

Shortcut Keys

For faster storage and recall of data without viewing the Notepad, press <Ctrl+Enter> instead of <Enter> after selecting one of the eight Groups.

2.3.5 Disk menu

Select either the removable hard drive or the floppy disk to save or load data.

Notes on naming data files

When saving data, filenames must contain only the letters A-Z, digits 0-9, and the following characters:

`_ ^ $ ~ ! # % & - { } () @ ' " ;`

Filenames cannot contain spaces; spaces typed into filenames are replaced by underbars (`_`). The filename is searched for disallowed characters. If any are found, the message “Bad characters in filename” appears, the offending characters are removed, and the filename prompt re-appears.

Before data files are saved to disk, the Setup directory is searched for a file with the same name. If there is already a file with the same name, the message “File Exists. Overwrite Y/N?” appears. Press ‘Y’ to overwrite data, or any other key to return to the filename prompt.

If a file cannot be saved because of disk problems, the message “No such file or directory” appears. Some of the reasons for this include:

- Disk not present or not installed in drive completely.
- Unformatted disk.
- Disk is full.
- Disk is write-protected (sliding tab on floppy disk shell)
- Disk is not proper type (High density 1.44M diskettes must be used)
- Bad Sector(s) on disk.

2.3.6 dElete

Data files on disk which are no longer be needed may be deleted. Press **dElete** from the Disk menu, select a file to delete, and press <Enter>. Once a data file has been deleted, it cannot be recovered.

2.3.7 Save All

In v. 2.3 Stereo and Multi-channel, the **Save All** command provides a convenient means of saving to disk data from all Branches. The Branch names are used as the filenames. This command backs up your data so that an inadvertent system reset will not cause a loss of data.

2.3.8 Load All

In v. 2.3 Stereo and Multi-channel, the **Load All** command searches the Setup directory for any files matching the present Branch names. Each file that matches a Branch name is loaded into that Branch.

2.3.9 save Ascii

Frequency response data may be saved as an ASCII file for post-processing and analysis in math programs or other applications. The resulting ASCII data table is tab-delimited and includes real and imaginary parts, coherence and data validity flags for each frequency bin. A sample ASCII data file may be found in the Appendix.

2.3.10 Panel

Pressing **Data Panel** displays a table of all the stored data in all the Branches, labeled with name, Group number, and the first 10 characters of the Notepad. In v. 2.3 Stereo and Multi-channel, each Group’s Procedure name also appears.



Figure 27 — v. 2.3 Multi-channel Data Panel Screen Display

2.3.11 Notepad

Whenever data are stored or recalled, a Notepad appears, allowing three lines of text to be entered, annotating the data.

In addition, the Notepad displays the following:

- Branch number
- Group number
- Procedure in which data was stored
- Microphone name
- Speaker status (which speakers were on)
- Averaging type and number
- Amplitude threshold
- Coherence threshold
- Time and date that the data was stored
- Internal Delay Time
- Venue
- Artist
- Engineer's name

All of these Notepad items stay with the data when it is saved to and loaded from disk. The Notepad may be skipped when storing and recalling data; see <Ctrl+Enter> shortcut key, above.

v. 2.3 Stereo and Multi-channel

2.3.12 Viewing Memory Data

Data recalled from memory will normally match the type being viewed. For example, if you are viewing a Room response, selecting **Data Recall** brings up Room memory traces. In Group view, Room, Eq, and Result memory traces are displayed.

However, these defaults may be easily overridden. Any recalled memory trace may be viewed by using the **View Memory** menu. For example, a Room memory trace may viewed along with a live Eq trace. See “Memory Tracking”.

2.3.13 Memory Tracking

In v. 2.3 Stereo and Multi-channel, Memory Tracking conveniently automates commonly used memory views. There are two types of Memory Tracking, Room/Eq and Branch Compare.

Room/Eq

Room/Eq Memory Tracking works as follows: In Eq view, the Room memory traces are recalled, and in Room view, the Eq memory traces are recalled (Result view recalls Result traces). This feature is useful during system equalization. In Room/Eq memory tracking, all data are recalled from the present Branch.

Branch Compare

During Branch Compare Memory Tracking, traces are automatically recalled from a “Compare” Branch. Each Branch can be assigned a Compare Branch; this is done in the Branch Setup Panel. Example: If Branch 1 and 2 are being compared to Branches 5 and 6 respectively, then Branch 5’s memory traces are displayed while Branch 1 is being measured, and changing to Branch 2 brings up Branch 6’s memory.

Memory Tracking is initially off, and is selected from the Data menu. When selecting Branch Compare Memory Tracking, you must also select which Branch you wish to compare the present Branch to.

Additional notes for v. 2.3 Stereo and Multi-channel

When storing and recalling data, the data are tagged with the name of the Procedure. These Procedure names appear on the Group 1-8 menu, the Notepad, and the data panel. This helps to organize the large amount of data that may be gathered when using multiple Branches, Groups, and Procedures.

2.3.14 Related Commands and Shortcut Keys

F5 (Freeze)

Pressing F5 stores live Frequency response traces to memory, replacing any memory traces already on screen. F5 is useful for quick A/B comparisons and other occasions when it is not necessary to keep the data in long-term memory.

F6 (Clear)

Pressing F6 clears memory traces.

F10 (Live/Memory Display Toggle)

This key is useful when you wish to quickly toggle between live and memory traces. Pressing F10 hides the memory traces. Pressing it again brings back the memory traces and hides the live traces; a third keypress restores both live and memory traces.

None of these three commands affect data stored using the **Data Store** command.

2.4 Setup Menu

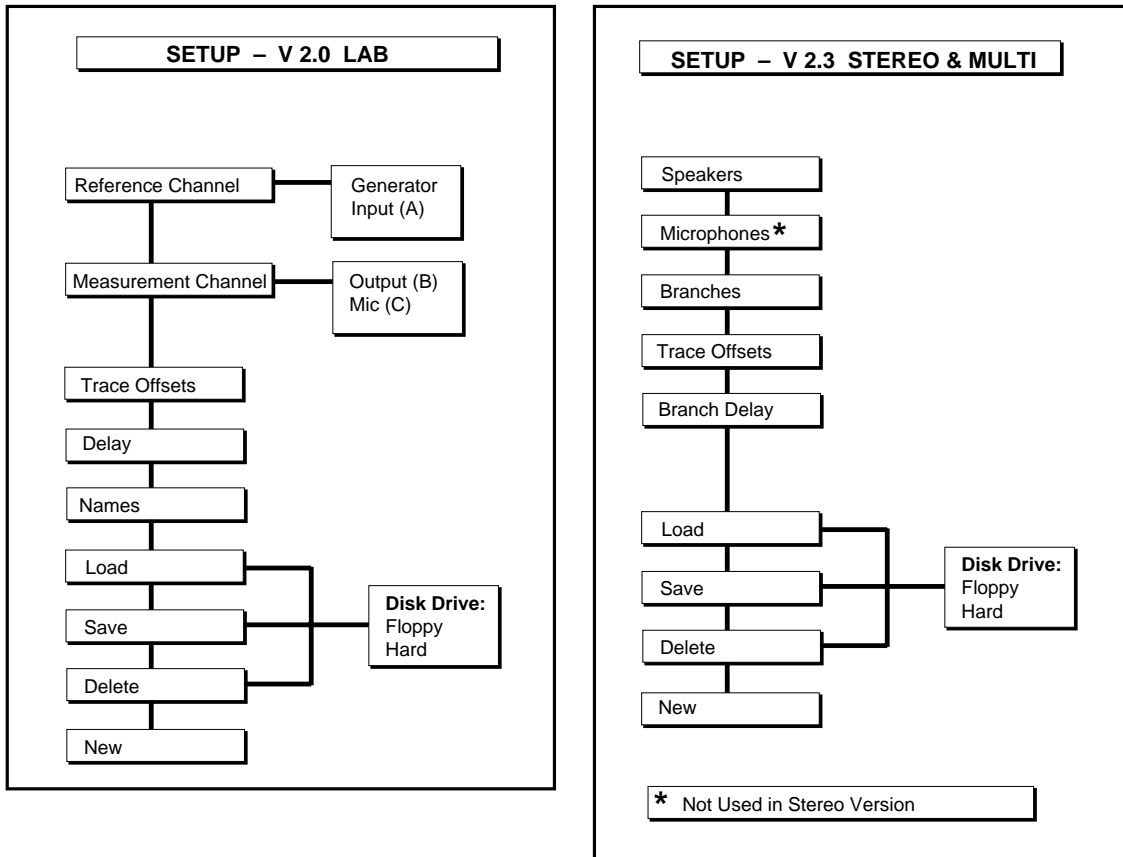

Figure 28 — Setup Menu Structure

The Setup menu customizes the SIM-2201 Sound Analyzer to conform to the system under test. All Setup data can be saved to disk and reloaded, allowing speedy restoration of the instrument state.

Within the Setup Panels, the keyboard functions are as follows:

Right/Left arrow	Move within field
Up/Down arrow	Move to field above and below
Ctrl+L/R Arrow	Move to beginning of next/previous word
Backspace	Delete previous character
DEL	Delete current character
Home	Move to first character in field
END	Move to last character in field
INS	Toggle insert mode
TAB	Move to next field
ESC	Restore field to last value before edit
ENTER	Accept entry and move to next field
CTRL+ENTER	Exit from panel

v. 2.0 Lab

2.4.1 Reference channel

The Reference channel can be set to Input (A) or Generator.

2.4.2 Measurement channel

The Measurement Channel can be set to Output (B) or Mic (C). Selecting Output (B) sets the system to measure a line-level electronic device. Instrumentation microphones that are preamplified may also be patched to Channel B.

Selecting Mic (C) sets the system to measure with a microphone or mic level device.

Channel A (Input) refers to the “device under test” input.

Channel B (Output) refers to the “device under test” output.

Channel C (Mic) is for microphones.

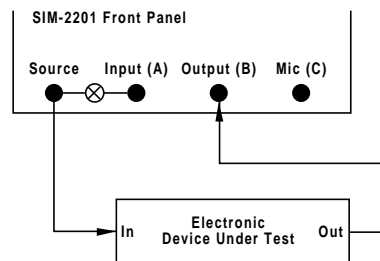

Figure 29 — v. 2.0 Lab Electronic Measurement with Generator as Reference Channel

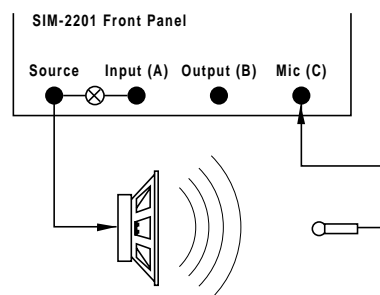

Figure 30 — v. 2.0 Lab Acoustic Measurement with Generator as Reference Channel

Select the Generator as the Reference when there is no need to use an unknown source. The system should be patched as shown in Figure 29 or 30.

v. 2.3 Stereo, v. 2.3 Multi-channel

2.4.4 Speakers

The Speaker Setup Panel must be configured to reflect the patching of the speaker system and measurement system. Type the Name of the speaker system corresponding to each of the Eq channels. This Name will be used in the Branch panel. Text areas annotate the speaker system type and location.

Speaker information is entered into the above fields so that the Speaker Panel is fully defined. The Speaker Name entered here will be used in the Branch Setup Panel. Each time the Speaker menu (See Procedure menu) is used, the Eq channel and Speaker Names will be displayed. The Speaker Name, Type and Location fields are saved in the Setup file.

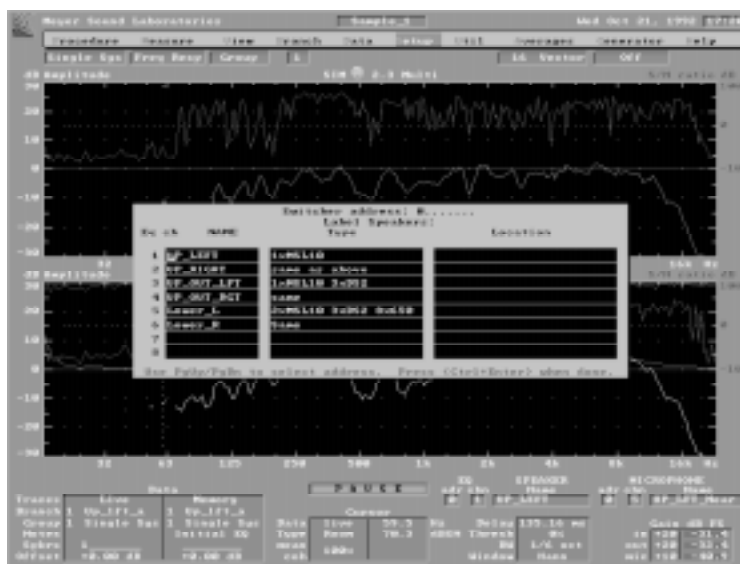

Figure 34 — Setup Speakers Screen Display

Multiple SIM-2403 access — Each Speaker Panel contains labeling for the eight channels of one SIM-2403 Interface Network. When addressing multiple Interface Networks, it is necessary to input the speaker and microphone Names on the panel for that address. Use Page Up/Down keys to see the Panel for the next/previous address.

2.4.5 Microphones

Type the Name of the microphone corresponding to each of the measurement microphone inputs to the SIM-2403 Interface Network. This Name will be used in the Branch Setup Panel. The Microphone Name, Type and Location fields are saved in the Setup file.

2.4.6 Branches

Branch Naming

Type the name of each Branch into the Branch Name field. This Name will also serve as the Branch's filename for the data storage. (See also Section 3.2 Branch Menu.)

Important note: You must name each Branch for which you wish to save Frequency response data.

Editing Addresses and Channels

For each named Branch in the system, the measurement points must be defined. Each Eq and Microphone must have its Address (0-7) and Channel (1-8) defined. The Cursor may be moved to the Eq and Mic channel fields for each Branch and the appropriate number entered. The labels for speaker and microphone will be updated as new channel numbers are entered.

Exiting the Branch Setup Panel

Pressing <Control+Enter> will return you to the main menu bar display.

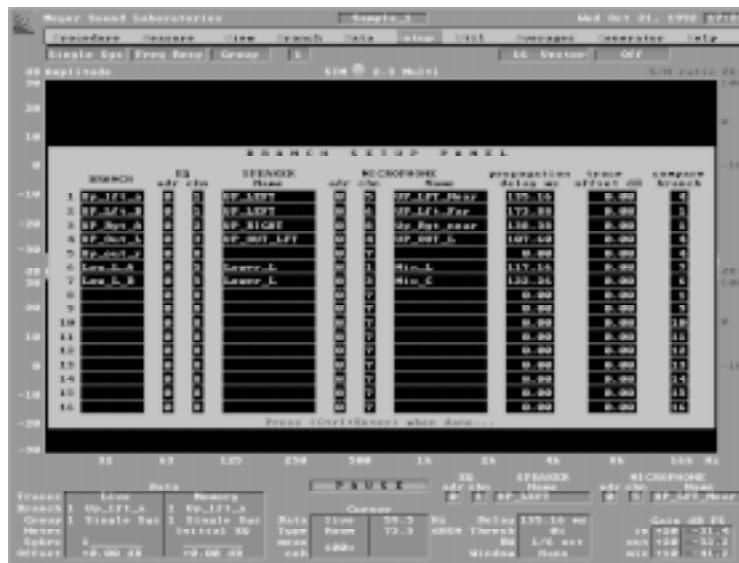

Figure 35 — Setup Branches Screen Display

2.4.7 Delay

The Delay Setup Panel allows you to enter the Internal Delay Time for a Branch. This might be done when estimating delay times before measurements are made.

2.4.8 trace Offset

The Trace Offset function repositions the amplitude response traces for convenient viewing and comparison. Trace Offset is entirely a video function, and does not change the values of the Frequency response measurements. Nor does it affect the input range (as do the **Util: Gain** controls). All data are stored and recalled with their actual amplitude values, but can be displayed with an offset. The offset range is ± 12 dB. If the trace is more than 10 dB off from the desired position, it is best to use **Util: Gain** so as to preserve dynamic range. (In v. 2.3, the Trace Offset is applied to Room and Result amplitude traces.)

Shortcut keys

+ or = increases offset 1 dB. - decreases offset 1 dB.

Note: The amplitude shown by the Cursor is its measured value, not inclusive of the offset.

2.4.9 saVe

This command saves the Setup file to disk. The Setup file includes:

- Data for each Branch, including the Branch Name, Speaker and microphone addresses and channels, Internal Delay Time, Trace Offset, Compare Branch and Notepad;
- Speaker and Microphone Names, Types and Locations;
- Venue, Artist and Engineer's name;
- Average number and type;
- Master Gain, Mic Gain, all vertical scales, Smoothing and Coherence threshold.

Setups can be saved to either the floppy or the hard drive. You will be prompted for a filename. The Setup filename will serve as the subdirectory name under which your present data files can be stored, so it is always necessary to save a Setup **before** saving data files. Type in the name and press <Enter>. The directory of Setup files on the disk will be searched. If the name is unique, the Setup will be saved. If there is a file with the same name, a prompt will appear:

Overwrite Yes or No?

If the **Y** key is selected, the new Setup will overwrite the old one. Any other key will return you to the filename prompt.

If the file cannot be saved, you will be alerted by a prompt stating:

No such file or directory

The reasons that a file cannot be saved include:

- Disk not present
- Unformatted floppy disks
- Disk full
- Write protected disk
- Not a High density floppy disk
- Bad sector(s) on disk

Setup file size

The Setup file size ranges from 1.9 to 9.8 kbyte, depending upon the number of Branches used.

2.4.10 Load

Select the disk having the desired Setup file. You will be prompted with a list of the Setup files on the disk. The Up/Down arrow keys will select the desired file. Page Up/Down keys select additional pages of files if required. Press <Enter> to Load the desired data file.

The Setup will load from disk, and the Branch Setup Panel will show the new Setup. You may change any entries if you desire. In addition, the other parameters listed above will be recalled.

If the selected disk is not present, a prompt will appear as described above in the section on **Setup: saVe**.

After the Setup has been loaded a prompt will appear regarding the data array. You may choose to load the data array that corresponds to the newly loaded Setup as well, to clear the array, or to continue with the old data still present.

Load: Clear old data — Clears the Frequency response data array in memory so that the next cycle of measurements may begin with a clear array. This has no effect upon data that have been saved previously to disk.

Load: Load all data — Loads the Frequency response data from disk for all Branches using the present Branch names as filenames.

Load: cOntinue — Allows the Setup to be reset without clearing the Frequency response data array. Note that if the old data remain in memory they are no longer labeled with their original Branch names.

2.4.11 dElete

Deletes the Setup file from the directory. If there are data files present a prompt will appear asking:

Delete X Branches in Setup <Setup filename>

Yes No

(X is the number of data files to be deleted.) If **Yes** is selected, the Setup file and its data will be deleted. If **No** is selected, the Setup file will not be deleted.

2.4.12 New

This command resets the Setup Panel to the default setting.

- Names are cleared.
- Internal Delay Time(s) set to 0 ms.
- Trace Offset(s) set to 0 dB
- Compare Branch numbers reset to default settings

Utility and Average parameters such as Gain and Smoothing are not affected by this command.

After the Setup has been cleared, a prompt will appear regarding the data array. You may choose to clear out the data array as well, or to continue with the old data still present.

2.4.12.1 New: Clear old data

Clears the Frequency response data in memory so that the next cycle of measurements may begin with a clear array. This has no effect upon data that have been saved to disk.

2.4.12.2 New: cOntinue

Allows the Setup to be reset without clearing the Frequency response data array. Note that if the old data remains in memory, it is no longer labeled with its original Branch names.

2.4.13 Default Setup

The system boots up with its own default Setup. This Setup is intended to provide a logical starting place so that the minimum amount of time need be spent filling out the Setup Panel. There are different default Setups for the Lab, Stereo and Multi-channel programs.

2.5 Util Menu

The **Utilities** menu contains sub-menus that control the global parameters of the instrument.

2.5.1 Vertical Scale

Sets the vertical scale for the displays.

2.5.1.1 Spectrum Vertical Scale

Amplitude in dB/div — The amplitude scale is always referred to dB full scale. 0 dB is at the top of the screen.

2.5.1.2 Delay finder Vertical Scale

Amplitude in units/div — 0 is always at center; a value of 1 implies unity gain.

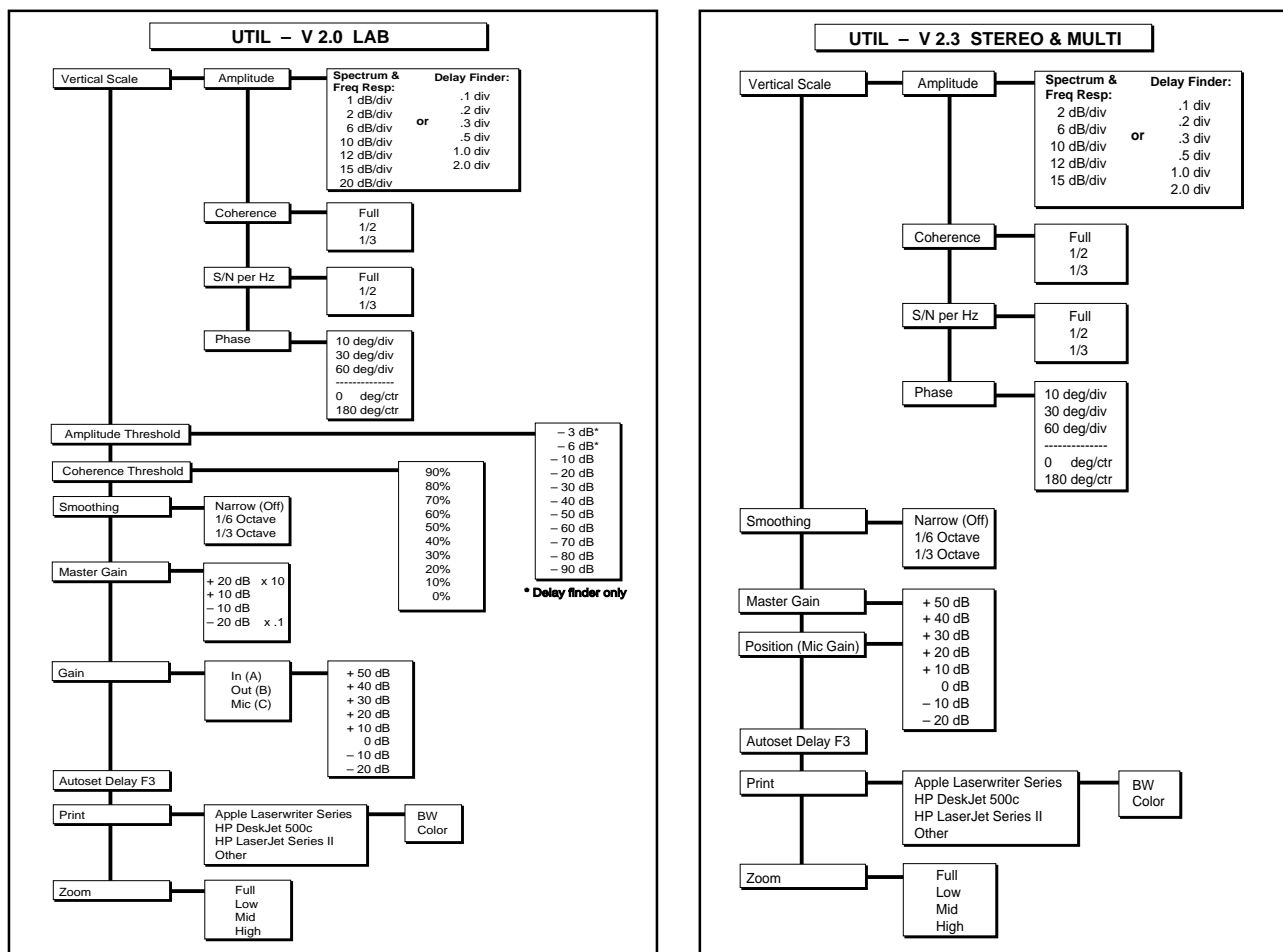

Figure 36 — Util Menu Structure

2.5.1.3 Frequency response Vertical Scale

Amplitude in dB/div — The amplitude traces are typically centered with unity gain at the screen center.

v. 2.0 Lab — The vertical scale is offset when the gains of the Reference and Measurement channels are different.

Coherence — The Coherence scale shows 100% at the top of the screen, and may be adjusted for full, ½ or ⅓ screen.

S/N per Hz — The signal-to-noise scale shows +100 dB at the top of the screen, and may be adjusted for full, ½ or ⅓ screen. Signal-to-noise is calculated at maximum frequency resolution, regardless of the smoothing setting.

Phase in degrees/div — The phase scale typically shows 0 degrees at the center, but can be changed to 180 degrees at the center. This option is available only with vector averaging.

Util: Vertical scale: Phase: 0 degrees center

Util: Vertical scale: Phase: 180 degrees center

The vertical scales are independently adjustable, and are stored as part of the Setup file. You may choose either Coherence or S/N.

2.5.2 Smoothing

Smoothing can be applied to the Frequency response data.

- Only amplitude and phase responses are smoothed.
- All amplitude and phase traces are formatted the same (smoothed or not)
- All data are stored at full resolution, regardless of smoothing.
- Smoothing is never applied to Coherence or S/N traces.

Smoothing of the amplitude and phase traces is achieved by averaging above and below each of the frequency bins.

Narrow (1/24th Octave) — No smoothing or interpolation

1/6 Octave — Sixth octave smoothing and interpolation

1/3 Octave — Third octave smoothing and interpolation

2.5.3 Master Gain

The Master Gain menu sets the gain of the Eq In (A), Out (B) and Mic (C) in 10 dB increments. Setting the Master gain optimizes the measurement system's gain structure to deal with different source levels. Changes in the Master gain will not cause any of the Frequency response traces to move up or down, since the Frequency response is sensitive only to the relative gain between channels. It *will* move the Spectrum response up or down, since the spectrum vertical display is referred to full scale input level. The default Master Gain is 0 dB for all channels.

v. 2.0 Lab

The Master Gain Menu selections refer to the gain relative to the present settings. For example, selecting +10 dB will increase the gains of channels A, B, and C by 10 dB.

v. 2.3 Stereo, v. 2.3 Multi-channel

The Master Gain Menu selections refer to the actual gain settings of the Eq and Mic channels. They are listed in separate columns. For example, selecting +10 dB on the Eq channels will set the gain of the Eq channels to +10 dB. The gain of the Mic channel will maintain its relationship with the Eq channel.

Setting Master Gain

The gain for each channel can be set by first viewing the levels of the incoming data, as displayed in the Input Status Area on the screen (or the front panel meters), and adjusted so that the input level is within 10 dB of full scale input drive. If the gain is too high, an overload will be indicated and the data will be rejected. If the gain is too low, the input level will read consistently lower than -10 dB FS (full-scale), and the effect of the Amplitude threshold will cause data acquisition to be slowed. For signals with wide dynamic range, bear in mind that an occasional overload is tolerable, as data are rejected.

Shortcut Keys

v. 2.0 Lab — No shortcut key for master gain. <Shift> F1-F6 may be used to set individual gains.

v. 2.3 Stereo, v. 2.3 Multi-channel — <Shift> F1/F2 move master gain up/down 10 dB.

2.5.4 Gain: A, B, or C (v. 2.0 Lab only)

Controls the gain of the selected channel only, in 10 dB increments. Changes in gain of any one of these channels will cause the Frequency response traces to move up or down. The vertical scale will be redrawn to reflect the offset in gain. The gain for each channel can be set by first viewing the levels of the incoming data, as displayed in the Input Status Area on the screen (or the front panel meters), and adjusted so that the input level is within 10 dB of full scale. Precise control of the trace position is effected using **Setup: trace Offset** in the Setup Panel.

2.5.5 Position (Mic Gain — v. 2.3 Stereo and Multi-channel only)

The Position menu controls the gain of the mic channel only. It is used during Setup as a coarse vertical positioning control to compensate for the acoustical gain of the loudspeaker system at each microphone point. Fine control of the trace position is effected using the **Setup: trace Offset**.

By setting the Mic channel gain separately from the Eq In and Out gain, one can compensate for the relative gain of the Speaker/Mic system. Changes in the mic gain will cause the amplitude response traces of the Room+speaker and the Result Types to move up or down. Since a change in mic gain causes a change in the position of the trace on the screen, it is advisable to find a single setting that best suits the average gain level of the different Branches. Otherwise, it can become difficult to keep track of the actual gain relationships between sub-systems. The Position can be set by viewing the input levels of the incoming data, and adjusting so that the Mic input level most closely matches the Eq In and Out levels. The relationship between the Eq Input and Eq Output gain and the Mic Gain is changed only when the Mic Gain is changed — not the Master gain.

Shortcut Keys

<Shift> F5/F6 move position (Mic Gain) up/down 10 dB.

2.5.6 Autoset Delay (F3)

This function is available only in the Delay finder. The Internal Delay Time is set to the Cursor position.

2.5.7 Amplitude threshold

The Amplitude threshold is designed to improve the signal-to-noise ratio of Frequency response measurements by pre-screening the incoming data. The level at each frequency bin in the Reference channel is checked against the threshold, and only data at those frequencies that clear the threshold are used for computation. This is particularly useful for sources such as music, where the density and frequency content of the incoming signal is variable. The Amplitude threshold is adjustable for Frequency response and Delay finder measurements in v. 2.0 Lab.

2.5.8 Coherence threshold

Coherence thresholding blanks Frequency response data at frequencies where there is a low signal-to-noise ratio. The Coherence threshold ranges from 90% to 20%, depending upon the number of averages selected. This threshold can also be expressed as Signal-to-noise ratio in dB. Its relationship to the averaging number is as follows:

<u>Avg. #</u>	<u>Coh Thresh</u>	<u>dB/SN</u>
2	90%	+20 dB
4	60%	+3.5 dB
8	40%	-3.5 dB
16	20%	-20 dB

In v. 2.0 Lab, the Coherence threshold is adjustable for Frequency response measurements in 10% increments.

Note: The setting for the Coherence threshold is valid only for the current number of averages. Each time the Average number is changed, the Coherence threshold value automatically resets to the default value.

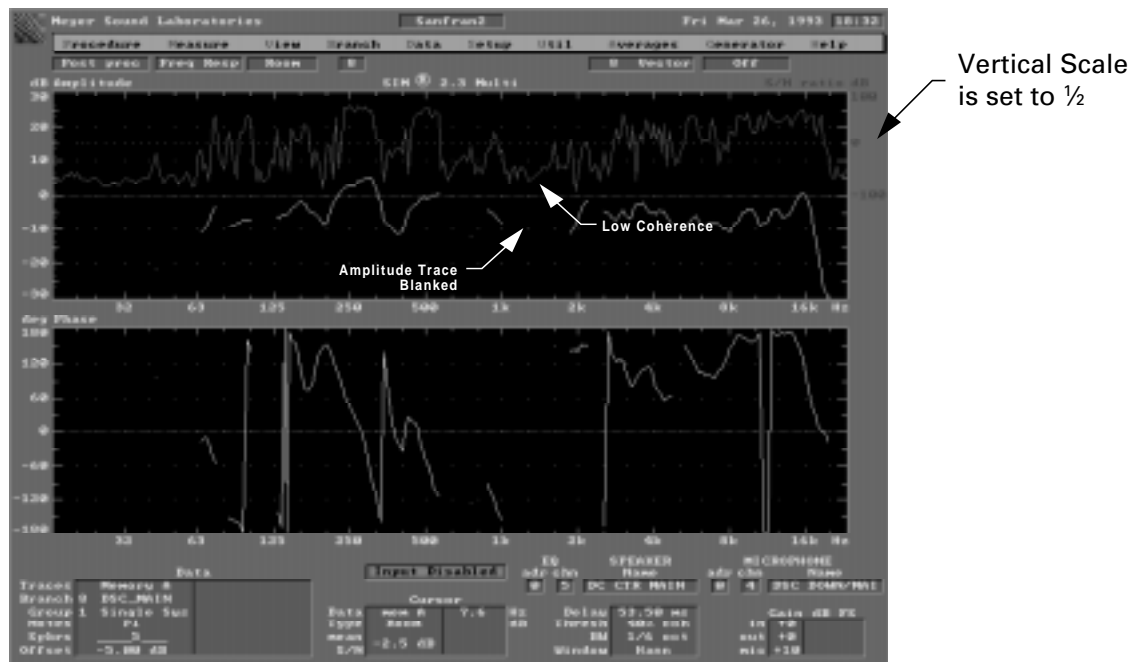

Figure 37 — Coherence Blanking

2.5.9 Zoom

This is a video display function designed to allow easier viewing of Frequency response data within a specific range. Zoom is not available in Spectrum or Delay finder measurements.

There are four range selections:

- **F**ull — Full range (7.6 Hz-22.634 kHz)
- **L**ow — 7.6 Hz -200 Hz
- **M**id — 125 Hz-2 kHz
- **H**igh — 1 kHz -22.634 kHz

Shortcut Keys

<Control+Page Up/Down> keys serve as shortcut keys for **Z**oom as a four-position toggle.

Command Sequence:

*Util: Zoom: Range select (**F**ull, **L**ow, **M**id, **H**igh)*

v. 2.0 Lab

The Zoom function doubles the number of lines of resolution in Frequency response measurements. This increases the effective bandwidth of the measurements to greater than 1/30th octave.

v. 2.3 Stereo and v. 2.3 Multi-channel

The Zoom function is a display function only and has no effect upon the number of lines of resolution in Frequency response measurements.

2.5.10 Print

The Print utility is used to make hard copy for publication or presentation. Printouts occupy approximately half a standard 8 1/2" by 11" page.

The printer must be connected to the parallel port on the rear panel marked "Printer." A standard D25 fully-wired pin-to-pin cable will make the proper connection.

Printer model selection

The system will prompt you to select a printer. The following printers are permanently installed:

Apple LaserWriter Series
HP DeskJet 500c
HP LaserJet Series II
Other:

Press <Enter> to confirm your selection.

The **O**ther printer is user-installable. Installation of a user-selected printer is described in Section 2.0.5.

Print format selection

Once a printer is selected, a sub-menu will prompt you to select color or black and white mode.

B/W — Black and white (no grey scale)
Color — Prints color on the **H**P DeskJet 500c or other color printers, and grey scale on monochrome printers.

2.6 Averages

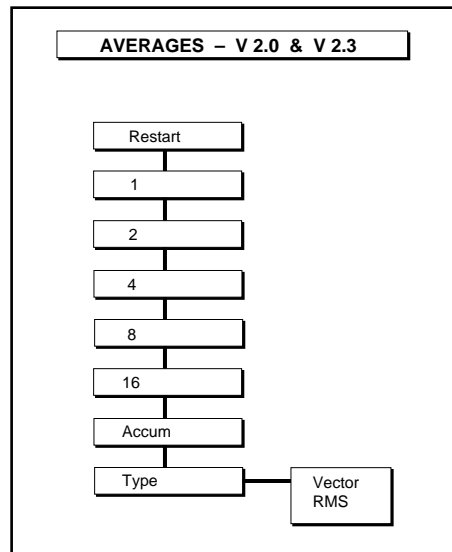

Figure 38 — Averages Menu Structure

SIM System II utilizes a unique form of averaging implementing Amplitude thresholding. The threshold function serves to avoid some of the common inaccuracies of FFT analyzers when an unknown excitation is used.

The instantaneous amplitude and phase values are shown as yellow dots. The averaged values will not appear until each frequency bin contains at least the number of averages selected.

2.6.1 The Averaging Menu

The Averages menu selects the number of averages and the average type.

The numerical selections are:

- 2,4,8,16 (First in first out)
- Accumulator

FIFO (First In First Out) averaging uses the last N (2,4,8 or 16) samples and divides them by N. When more than N samples have been obtained, then the oldest of the samples is deleted and the new one is added in. This provides a continuously updated averager. No weighting function distinguishes among the data; all data are treated equally. Until the averager has N samples for a frequency bin, only the incoming instantaneous Frequency response data for that bin (yellow dots) will be shown. After N samples are obtained for a bin, the averaged data will be displayed as a trace.

The principal advantages to this type of averaging are that:

- each frequency bin has the same number of samples, and
- no restart is required when system adjustments are made.

Fewer averages will yield faster display of the measured data at the expense of greater stability and accuracy. Measurements substantially contaminated with noise should use more averages. (Systems in reverberant halls, for example, will require more averages than near-field measurements in quiet environments.)

In the **Accumulator** type of averaging, all data samples are averaged until a **Restart** command flushes out the averager. As each new sample comes in, it is added to the others, the sum of which is divided by the accumulated number of samples.

Accumulator averaging yields very quick display and increased stability with more samples. It has three distinct disadvantages from FIFO averaging:

- Each frequency bin contains an unknown number of samples.
- Later averages have very little effect on the total. This means that if the system under test changes, the change will be barely detectable.
- A **Restart** is required any time the system under test changes.

The **Accumulator** averaging option is available in **Measure: Delay finder** for all system software versions. In v. 2.0 Lab, the Accumulator is also available for Frequency response measurements.

Regardless of which averaging type is chosen, an automatic Restart will occur whenever:

- The **Branch** is changed
- The Internal Delay Time is changed
- The **Position** (Mic Gain) is changed
- The Speaker **Selector** is changed
- The Branch, Eq or Microphone **Setup** Panels are edited

This prevents the averager from containing data of different sources or types.

2.6.2 Average Menu Selections

Restart — Restarts averager and clears out all previous samples from the averager (Shortcut key “R”).

Numerical Selections — Select the number of averages.

Accum — Accumulating average, limited to 999 samples (available in v. 2.0 Lab Frequency response, and in all versions for Delay finder).

Type — Selects averaging type.

- **Vector** — Selects Vector Averaging, which affords the best rejection of contaminated data. It requires an absolutely stable time relationship between channels, and works well for indoor applications
- **Rms** — Selects RMS (Power) Averaging, which affords less rejection of contaminated data. RMS averaging is more tolerant of time variance between channels. It is preferable for outdoor applications, or when speakers or mics are moving slightly. Coherence blanking is disabled.

Default Average settings

- | | |
|---|--------------|
| • Average: num./type — Measure: Spectrum | 1 RMS |
| • Average: num./type — Measure: Delay finder | Accum Vector |
| • Average: num./type — Measure: Frequency response. | 4 Vector |
| • Average: num./type — Measure: fEedback finder | Peak hold |
| • Average: num./type — Procedure: External Delay | 2 Vector |

Note: In v. 2.3 Stereo and Multi-channel, you may have a different number of averages for Room and Result types than for Eq and 1/Eq types. This allows more averages for acoustical measurements in reverberant environments (better noise rejection), and fewer for equalizer measurements (greater speed).

2.7 Cursor

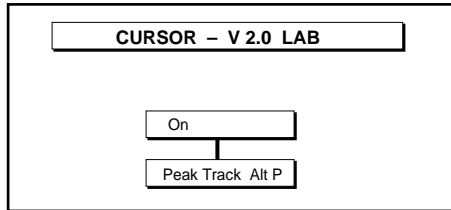

Figure 39 — Cursor Menu Structure

The Cursor appears as an “X” on the display, and can be placed on any of the traces. The description of that trace will then be found in the Cursor Status Area:

- **Type** Room+speaker, Eq, Result, Eq In, Out, Mic
- **Measurement Trace** Amplitude, Phase, Coherence
- **X-axis position** Frequency, Time
- **Y-axis value** dB, dBV, Degrees, % Coherence

The default status of the Cursor is Peak Tracking, in which the Cursor finds the highest value of the amplitude trace. (Peak tracking is not used on Phase traces.) The peak track function is updated with each new measurement cycle.

Left and Right arrow keys move the Cursor on the horizontal axis.

Control+Left and Right arrow keys move the Cursor on the horizontal axis by 24 bins (approximately one octave). If the **L/R** arrow keys are used, the automatic peak tracking function will be halted. To restore the peak tracking function, type **<Alt+P>**. The peak track function will be restored automatically any time the Measurement is changed.

The **Up/Down** arrow keys move the Cursor to the next/previous trace.

When a menu is open, the arrow keys are used for navigating among selections.

v. 2.0 Lab

On Turns Cursor on

Peak Track Enables peak tracking mode

2.8 Generator

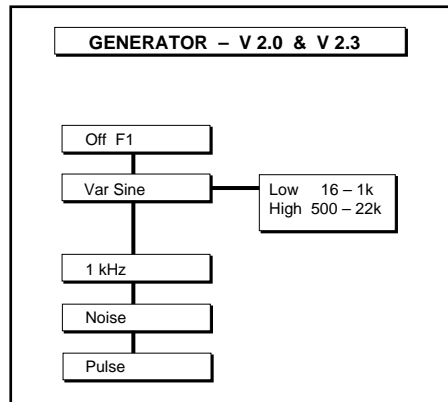

Figure 40 — Generator Menu Structure

The Generator serves as a convenient excitation signal when Source Independent Measurements are not required. Its output is capable of a maximum voltage swing of +26 dBV, and its source impedance is 300 Ω .

2.8.1 Off (F1)

Shortcut key **F1** turns off the Generator. Once the Generator has been turned off, you must select one of the Generator functions below to reactivate it.

2.8.2 Noise

Pressing **Noise** selects pink random noise with equal energy per octave. It is primarily used for Frequency response and Delay finder measurements.

2.8.3 Pulse

Pressing **Pulse** selects a pink filtered pulse at an average rate of 1.1 Hz. The interval ranges randomly from 0.9 to 1.3 Hz.

2.8.4 1 kHz Sine

Pressing **Sine** selects a 1 kHz sine wave for distortion and gain structure testing.

2.8.5 Variable sine

Variable sine is used for selectable sine frequencies and sweeps. Two frequency ranges are available: High and Low. The **Sine Freq** control is located on the front panel.

2.9 Help

2.9.1 Setup

Describes keyboard functions for the Setup panels.

2.9.2 Keys

Furnishes a complete list of the Shortcut keys.

2.9.3 Names

Shows the acceptable characters for filenames.

2.9.4 Info

Gives version numbers of the software in use.

v. 2.3 Stereo, v. 2.3 Multi-channel

2.9.5 Procedure

Provides a brief guide to the Procedures menu.

Note: The Help menu text is maintained on the system disk as a separate file. If the program has booted from a SIM Software bootable floppy, that floppy must remain in the drive to access the help files.

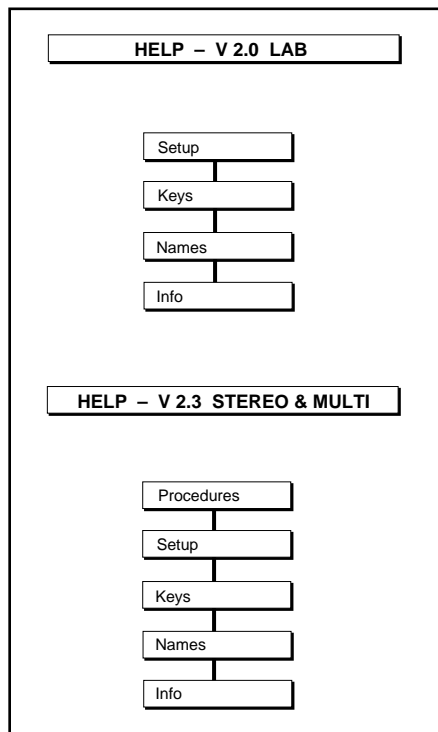

Figure 41 — Help Menu Structure

Section 3 — Stereo and Multi-channel Menus

3.1 View Menu

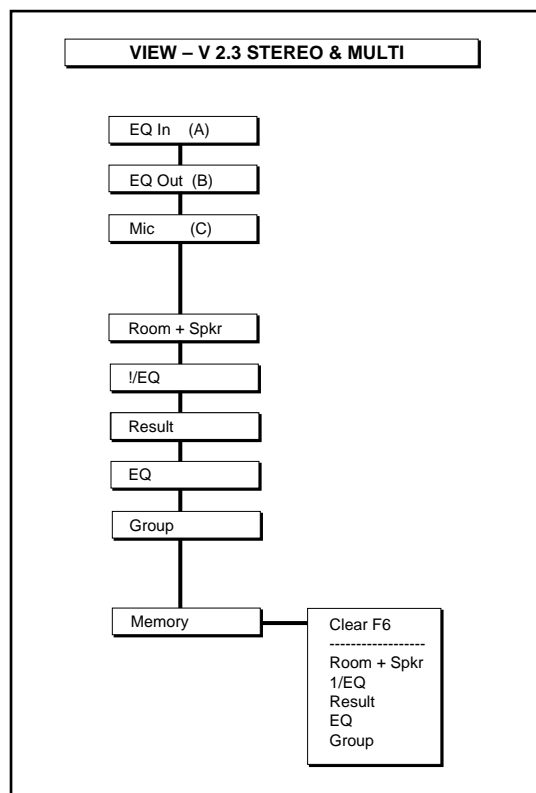

Figure 42 — View Menu Structure

The View menu selects the display format for the traces. Live traces and memory traces may be individually selected, or viewed together.

3.1.1 View Menu for Single Channel Spectrum and Feedback Find

Eq Input — Single channel amplitude spectrum of Eq Input.

Eq Output — Single channel amplitude spectrum of Eq Output.

Microphone — Single channel amplitude spectrum of Microphone.

3.1.2 View Menu for Dual Channel Delay Finder and Frequency response

Room+speaker (White) — Measurement of the unequalized loudspeaker/room system response.

Eq (Orange) — Measurement of the equalizer response. Measurements of this type may be made with the loudspeaker system muted, if desired.

1/Eq (Green) — Measurement of the inverse of the equalizer response. Measurements of this type may be made with the loudspeaker system muted. **View: 1/Eq is not available in Delay finder.**

Note: Only one of the Eq view selections (Eq or 1/Eq) is available at a time.

reSult (Blue) — Measurement of the equalized loudspeaker/room system response.

Group — This is an amplitude and S/N (or Coherence) display of the Room, Eq and Result measurement types.

Memory —Selects which memory traces appear on the screen.

Command Sequence:

View: Memory: Select Type (Room+speaker, 1/Eq, reSult, Eq)

Default View settings:

Spectrum	Eq Input
Delay finder	reSult
Frequency response	reSult
fEedback finder	Eq Input

3.2 Branch Menu

SIM System II allows selection and measurement of up to 64 equalizers, speakers and microphones. To facilitate efficient system management, the equalizers, speakers and microphones may be linked together by defining **Branches**. The Stereo version of the SIM software accommodates two Branches, and the Multi-channel version accommodates sixteen.

The **Branch** menu selects a Branch for measurement. When a Branch is selected, the SIM-2201 and SIM-2403 automatically select the appropriate equalizer, speaker and microphone.

Each Branch has three measurement points:

- Eq Input
- Eq Output
- Microphone

From these, three transfer functions are calculated: Room+speaker, Eq and Result.

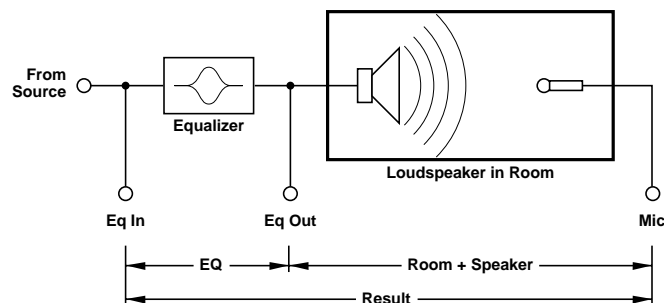

Figure 43 — A sound system Branch

Each Branch also has an associated delay time corresponding to the propagation delay between speaker and microphone. When a Branch is selected, the Internal Delay Time is set to the appropriate value.

Each Branch has a user-selectable Name. When data are stored and saved to disk, this Name serves as the filename.

To be fully defined, a Branch must have:

- Name
- Eq and speaker address, channel number and name
- Microphone address, channel number and name
- Delay time
- Trace Offset
- Compare Branch

Example

Left
0 1 Mains Left
0 1 Mix Pos
30.00 ms
+4.00 dB
Branch 2

These parameters may all be entered from the **Setup** Menu.

Each Branch also has eight memory Groups where Frequency response data may be stored. When a Branch's data are saved to disk, the eight data Groups are saved.

Shortcut keys

- <Alt> + <Alt> N selects the next Branch
- <Alt> - selects the previous Branch

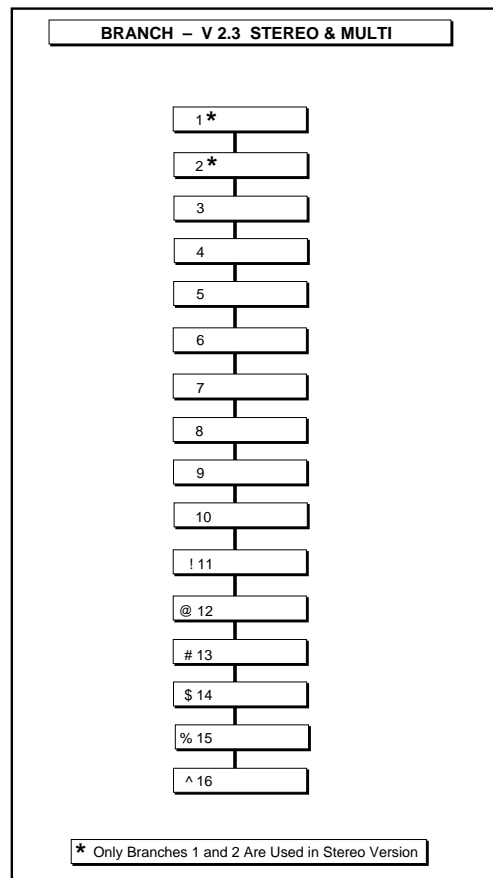

Figure 44 — Branch Menu Structure

3.3 The Procedure Menu

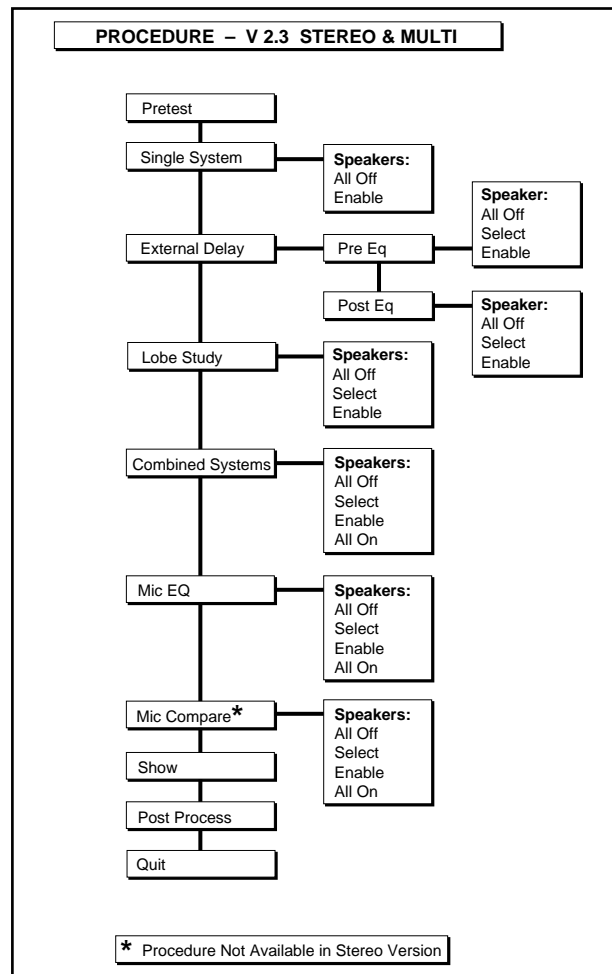

Figure 45 — Procedure Menu Structure

The Procedure menu guides the user through the major steps that constitute a complete analysis and adjustment cycle for a sound system, and the selections resemble a typical system alignment chronology. These Procedures are:

- **Pretest** — Setup, patching, verification of hookup
- **Single System** — Console output calibration, distortion analysis, polarity checking, initial equalization and gain adjustments of individual speaker subsystems.
- **External Delay** — Alignment of delay lines to synchronize speaker subsystems.
- **Lobe Study** — Examination of the relative isolation between speaker subsystems.
- **Combined Systems** — Gain adjustment and equalization of combinations of speaker subsystems.
- **Mic Eq** — equalization of individual microphones to be used in performance.
- **mIc Compare** — Analysis of individual microphones versus a known reference mic.
- **Show** — Measurement and adjustment of the system during performance.
- **pOst-process** — Examination and printing of previously collected data.
- **Quit** — Unmutes speakers, saves Setup, and exits program.

The Procedure menu sets global parameters to help guide the process. It does not, however, enforce a rigid protocol. Parameters are set primarily to alleviate the burden of having to design each set of measurements from scratch. An orderly categorization of data is effected so that tedious note taking is not required.

The Speaker menu (available from the Procedure menu) controls and keeps track of what speaker(s) are on.

The Procedure menu affects:

- Speaker control (muting)
- Internal Delay Time
- Measure menu
- Setup-trace Offset
- Generator (Source)
- Data-Store and Data-Recall

Note: It is impossible to fully describe the Procedure menu outside of the context of some specific applications. The scope of this text will be to give an overview of the Procedure menu. The SIM Applications Guide will serve as a reference for the specific techniques and system design criteria developed by Meyer Sound.

3.3.1 Pretest

The Pretest Procedure is used to establish that proper connections, signal flow and linearity are maintained in both the measurement system and the system under test.

Speakers — All On (speakers may not be muted)

Measure — Spectrum only

During Pretest Procedure, the engineer is able to unobtrusively “come on line” (hence no muting). Typical tasks include loading a Setup file (See Section **2.4 Setup Menu**) or creating a new one for the day’s job. After this is completed, signal is passed through the sound system to determine whether the system patch is correct.

3.3.2 Single System

The Single System Procedure incorporates speaker muting. Measurements performed in Single System will turn on only one speaker system at a time.

Applications include:

- Console drive level calibration
- System distortion measurements
- Setting the Internal Delay Time for each Branch, compensating for the propagation delay between the speaker and microphone
- Polarity verification
- Speaker system level setting
- Initial equalization

To make and store Single System measurements, follow these steps:

- 1) Select the Single System Procedure and enable the speaker (**Procedure: Single System — Speaker: Enable**).

- 2) **Measure: Delay Finder** — Set the Internal Delay Time.
- 3) **Measure: Frequency response.**
- 4) When the measurement is complete, you may store it in memory using the **Data: Store** (Single System) command.

3.3.3 External Delay

The External Delay Procedure is used to set an external delay line for the Branch being measured. The external delay line may be connected before or after the equalizer; the alignment sequence is different in each case. Delay finder is automatically selected during this Procedure.

Definitions

Delay Branch — The Branch that owns the Delay speaker and equalizer into which the External Delay Line is patched.

Reference Speaker — The speaker to which the Delay speaker is to be synchronized.

Post-Eq Delay Lines

If the external delay line is patched after the system equalizer, follow these steps:

- 1) Select the Delay Branch.
- 2) Set the external delay line to 0.0 ms (bypassed).
- 3) Select **Procedure: External Delay**, select **Post-Eq**, and select a Reference speaker. Press **<Enter>**. The Delay finder display should appear as shown in Figure 46a.

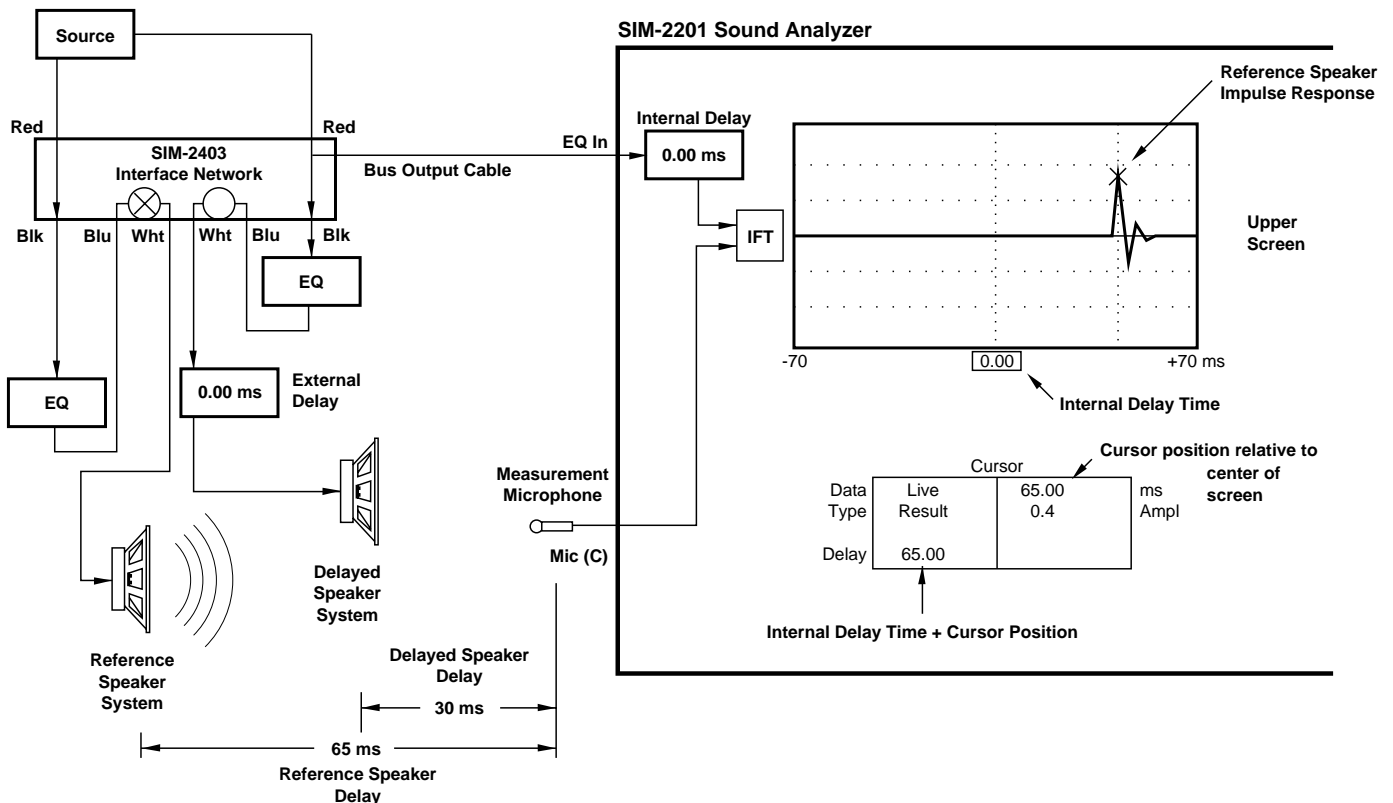

Figure 46a — Before Setting the External Delay. The Reference Speaker is Selected (Step 3).

- 4) Press **F3**. The Internal Delay Time will be set to compensate for the Reference speaker propagation delay, then the SIM-2201 will select the Delayed speaker and restart the Delay finder. The Delay finder display should appear as shown in Figure 46b.

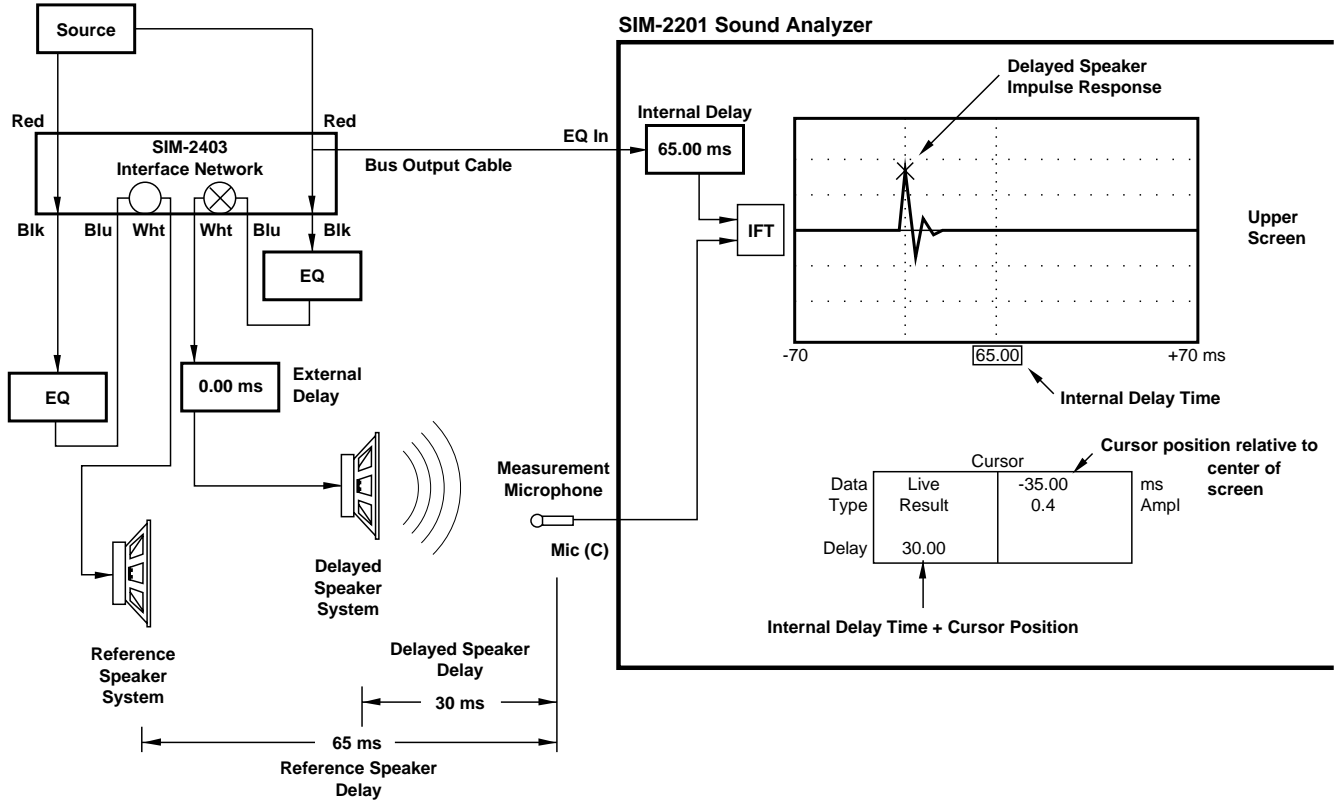

Figure 46b — Before Setting the External Delay. F3 has been Pressed. The Delay Speaker is Selected.

- 5) Adjust the external delay line time to the same number as Delay finder readout, highlighted in green in the cursor area (cursor position relative to screen center, labeled “ms”). The Delay finder trace will move as you adjust the external delay. (F3 is disabled after step 4.)

- 6) When the external delay time is properly set, the Delay speaker impulse response peak will be at the center of the screen, as shown in Figure 46c.

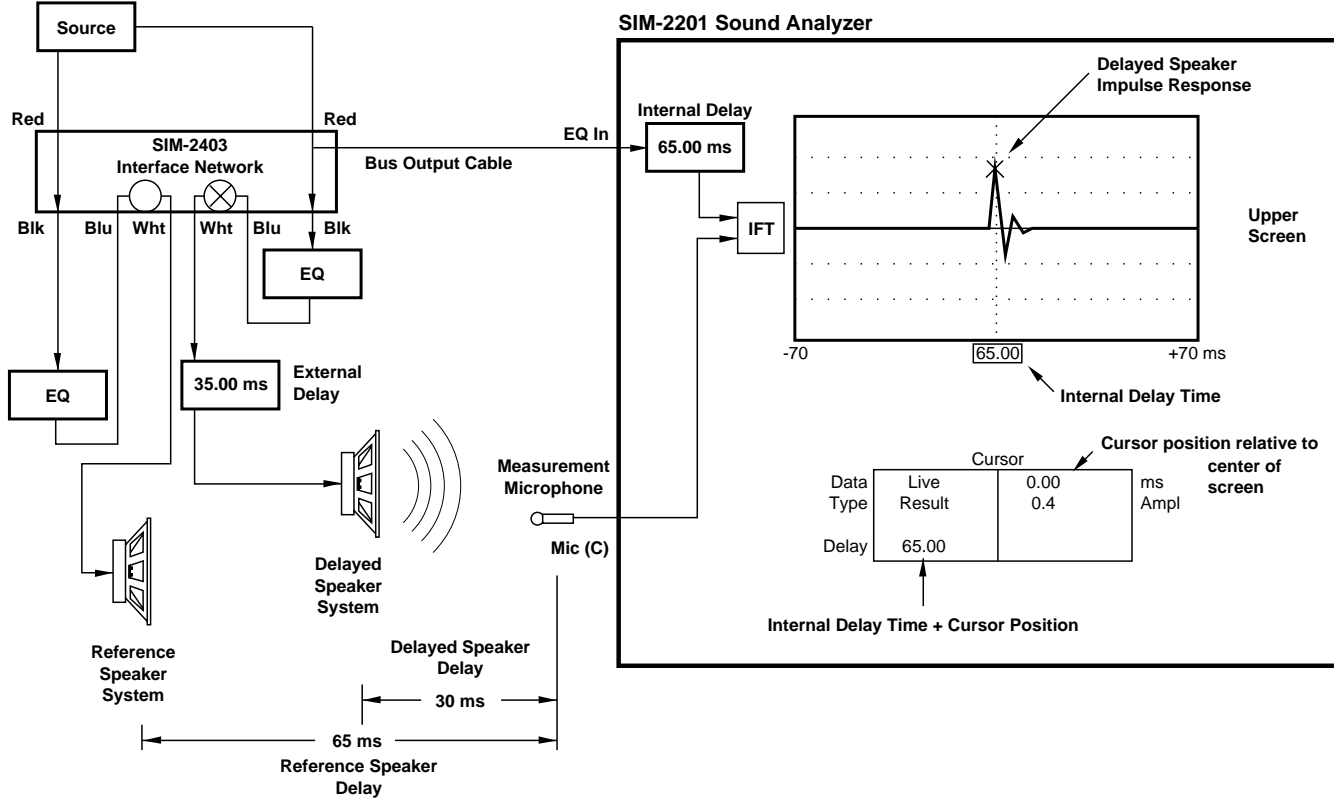

Figure 46c — After Setting the External Delay. The Delay Speaker Impulse Response Peak is Centered.

The external delay line has now been adjusted so that its speaker's sound will arrive coincident with the sound from the Reference speaker, at the measurement microphone position.

Pre-Eq Delay Lines

If the external delay line is patched before the system equalizer, follow these steps:

- 1) Select the Delay Branch.
- 2) Set the external delay line to 0.0 ms (bypassed).
- 3) Select **Procedure: Single System** and **Measure: Delay finder**. The display should appear as shown in Figure 47a.

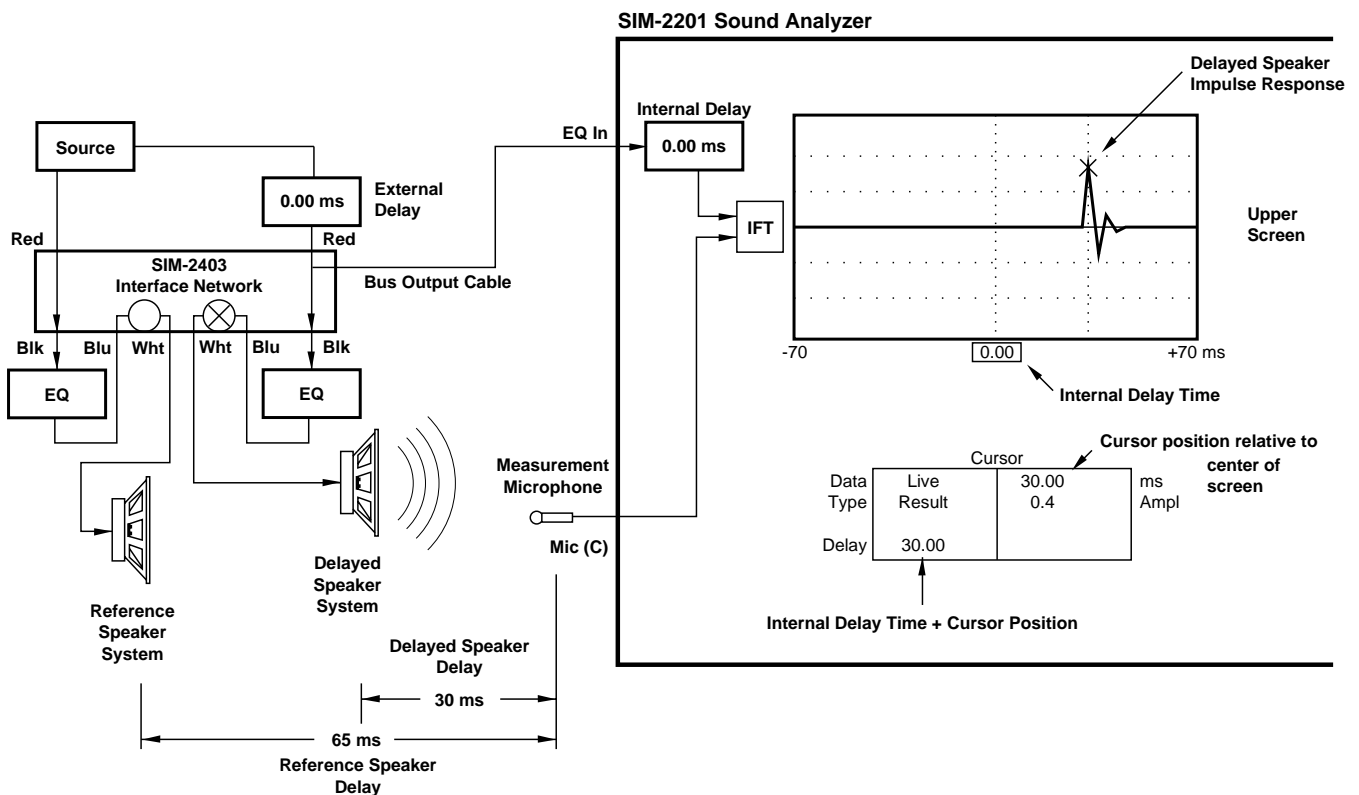

Figure 47a — Before Setting External Delay. In Single System Delay finder, Select Delayed Speaker Branch.

- 4) Set the Internal Delay Time for the Delay Branch to compensate for the propagation delay between the Delay speaker and the microphone by using **F3**. The display should appear as shown in Figure 47b.

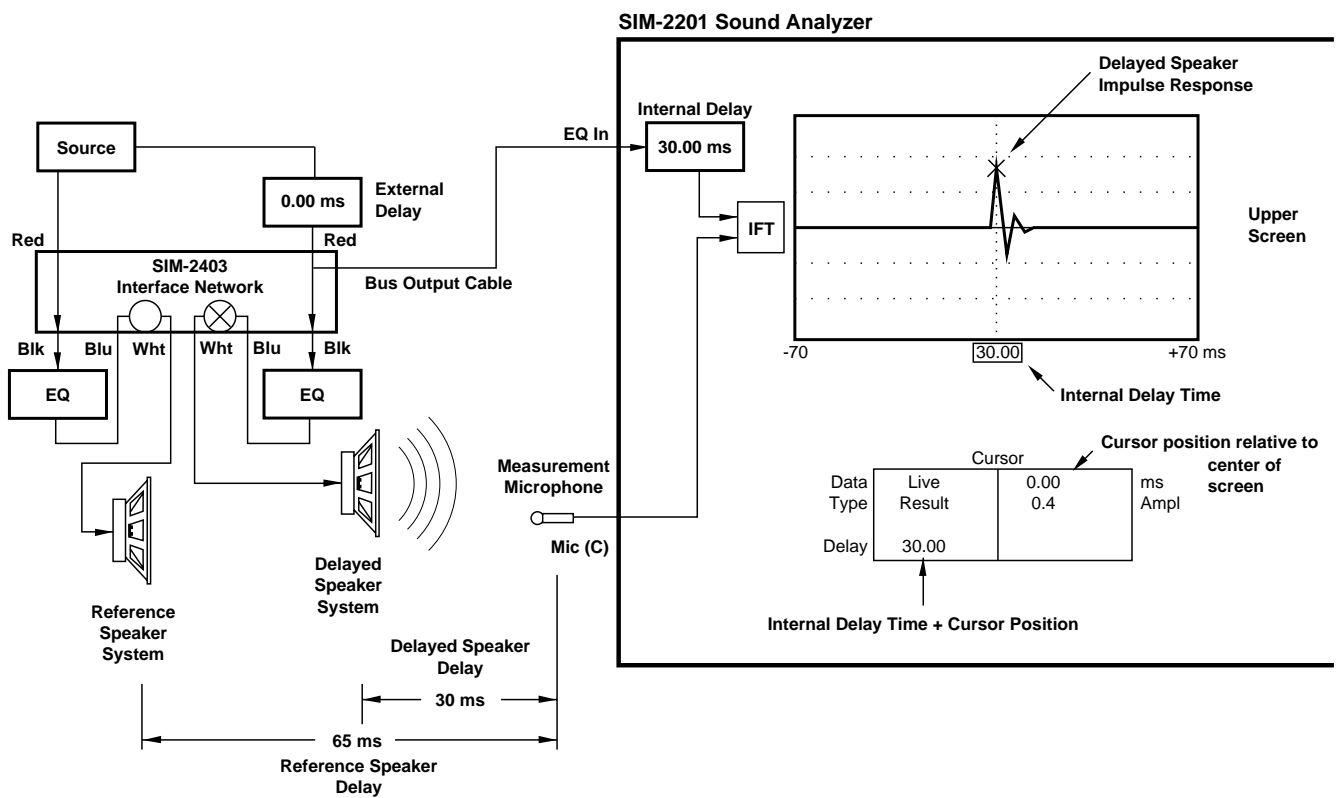

Figure 47b — Before Setting External Delay. Press F3 to Autoset Internal Delay Time.

- 5) Select **Procedure: External Delay**, select **Pre-Eq**, and select the Reference speaker from the Speaker menu. The display should appear as shown in Figure 47c.

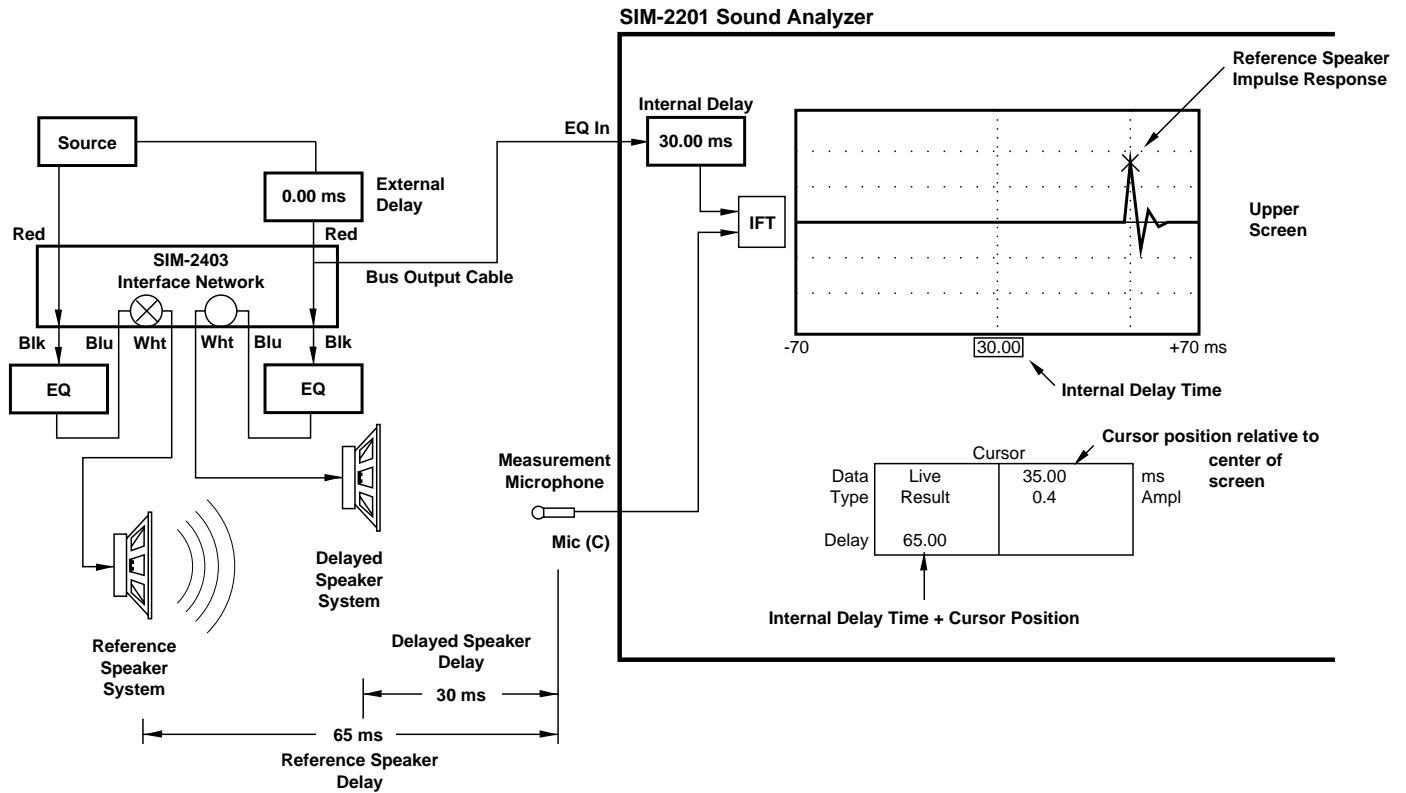

Figure 47c — Setting the External Delay. In External Delay Procedure, Select Reference Speaker.

- 6) While observing the Delay finder trace, adjust the external delay time until the peak is at center. The display should appear as shown in Figure 47d. The external delay line has now been adjusted so that its speaker's sound will arrive coincident with the sound from the Reference speaker, at the measurement microphone position.

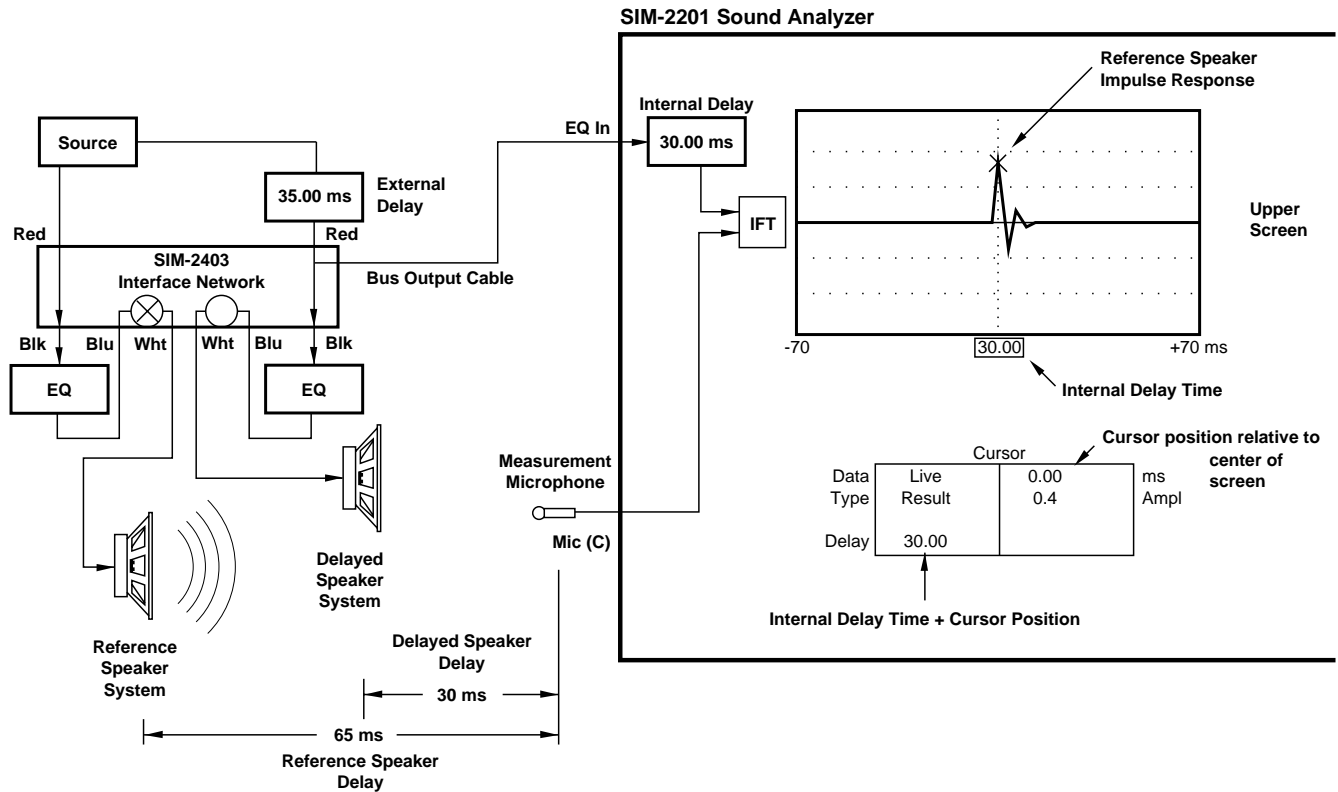

Figure 47d — Setting the External Delay. Adjust External Delay Until Cursor Peak is Centered.

Note: When using **Procedure: External Delay: Pre-Eq**, you will not be able to adjust the Internal Delay Time. This would cause errors in the computation of the external delay line time. The Internal Delay Time is always set to compensate for the propagation delay from the delay speaker to the measurement microphone.

3.3.4 Lobe Study

The Lobe Study Procedure is used to view the interaction from other speaker systems into the coverage area of the Branch being measured.

To make and store Lobe Study measurements, follow these steps:

- 1) Select the Lobe Study Procedure and select or enable the speakers (**Procedure: Lobe Study: Speaker: Enable or Select**).
- 2) **Measure: Delay Finder** — Set Internal Delay Time if necessary.
- 3) **Measure: Frequency response** (Trace Offsets are defeated).
- 4) When the measurement is complete, you may store it using the **Data: Store** (Lobe Study) command.

3.3.5 Combined Systems

The Combined Systems Procedure is used to add other sub-systems (such as delayed fill speakers) to the present Branch's coverage area and set their respective levels.

To make and store Combined Systems measurements, follow these steps:

- 1) Select the Combined Systems Procedure and select or enable speakers (**Procedure: Combined Systems - Speaker: Enable or Select**).
- 2) **Measure: Delay Finder** — Set Internal Delay Time if necessary.
- 3) **Measure: Frequency response** (Trace Offsets are defeated).
- 4) When the measurement is complete, you may store it using the **Data: Store** (Combined Systems) command.
- 5) You may also recall other data (i.e. Single System or Lobe Study) while viewing Combined Systems data. (**Data: Recall** — recall Single System or Lobe).

3.3.6 Mic Eq

The Mic Eq Procedure provides a way to measure and correct microphone responses similar to the Procedures for speaker systems, above. For those who want to measure the response of a microphone in its actual environs SIM System II provides an elegant solution. A typical application for this is a lavalier mic attached to a person. The SIM reference mic is placed at a conversational distance and becomes the "known" reference point in the measurements. The signal from the lavalier mic is fed through an outboard equalizer. The Eq Input and Output are monitored as usual. The switching is handled in software, and speakers are normally muted.

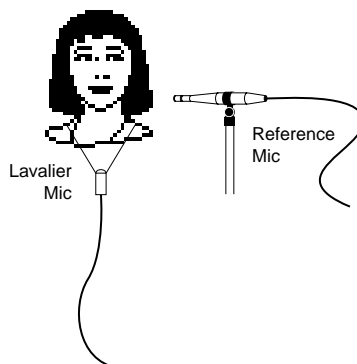

Figure 48 — Reference Mic Position for Body Mic equalization

In order to perform these measurements in actual practice they must be carefully executed. Because it is not possible to make these measurements while someone is walking around a stage, the person must remain at a fixed distance and angle to the reference microphone and to their own body mic. After the gains have been set proceed to **Measure: Delay finder** and set the Internal Delay Time. Move to **Measure: Frequency response**. Since the human voice is the generator, it is necessary to coax the person into speaking for long enough for you to obtain 4 to 8 samples at each frequency in the pass band of the human voice. This can take a while, so be patient and bear in mind that the averaging algorithm will hold the last valid samples received. It may seem silly, but by far the fastest method is to have the person either sing or simulate pink noise in various ranges. While it is possible to equalize the mic as the person speaks, it is usually more practical to store the Room+speaker Frequency response and equalize against the memory trace. After the Room+speaker data has been stored, enable the generator so that it flows through the equalizer for the mic channel. This will expedite the equalization process.

Figure 49 — Procedure: Mic Eq Signal Flow

Foot (Mouse) Mics

A popular technique in theatrical sound design is to use ground plane microphones to unobtrusively mic large stage areas where close proximity miking is not possible. The mics are placed low to floor to minimize the effect of floor reflections. It is possible to equalize these mics by comparing them against a reference mic in the near field. Any sound source can be used, human or a loudspeaker (a speaker is easier). The sound source is placed at a reference position and the reference mic is placed the desired distance from it. It is important that the two mics be placed so that they are both in the same axial plane of the loudspeaker to prevent the measurements from including the differences in axial response of the speaker.

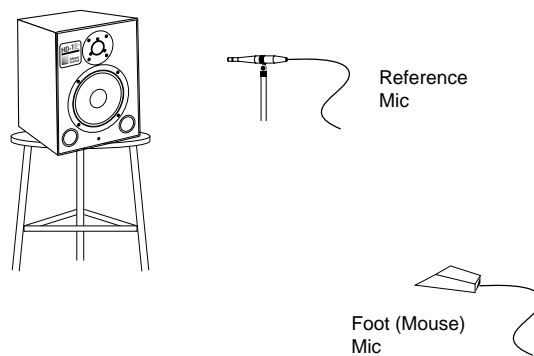

Figure 50 — Mic Placement for Foot Mic equalization

Connections should be made as shown in Figure 51. The procedure for equalizing the microphone is the same for both v. 2.3 Stereo and v. 2.3 Multi-channel, and is as follows:

- 1) In **Procedure: Pretest**, have the subject speak. If the sound source is loudspeaker, run noise through it. Adjust the console gain for optimum drive from the channel insert send output.
- 2) Using the Branch Setup Panel, establish a Branch with equalizer and Mic assignments that correspond to your connections. Measure this Branch.
- 3) Select **mic Eq** Procedure.
- 4) Adjust the Master gain and Mic gain so that signal levels are within 10 dB of full scale.
- 5) Select **Delay finder** under the Measure menu. Autoset (**F3**) the Internal Delay Time to compensate for the propagation delay between the microphones.
- 6) Select **Frequency response** under the **Measure** Menu, and select four or eight averages with the **Average** Menu.
- 7) Have the subject speak until a usable Frequency response is obtained.
- 8) Select **Store mic Eq** from the **Data** Menu.
- 9) **Recall** the stored data from memory.
- 10) Connect the Generator output to the console input in place of the lavalier or foot microphone, select **Noise** under the **Generator** Menu and adjust the level on the SIM-2201 front panel.
- 11) Select **Memory tracking: Room/Eq** from the **Data** Menu.
- 12) Select **1/Eq** from the **View** Menu.
- 13) Adjust the system equalizer to match the stored Frequency response.

Equalization of the microphone is now complete. Unplug the generator from the console input and re-patch the microphone.

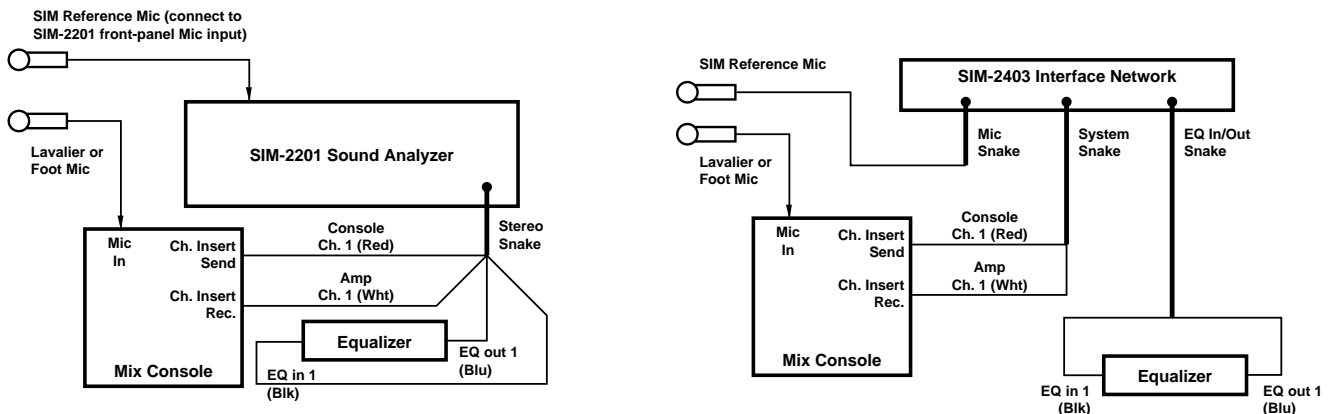

Figure 51 — Mic Eq Connections for v. 2.3 Stereo (Left) and v. 2.3 Multi-Channel (Right)

3.3.7 mic Compare (v. 2.3 Multi-channel only)

The Mic Compare Procedure allows for comparing different measurement microphones with a single reference microphone. The Reference microphone is plugged into the mic input on the front panel and routed internally to Channel A (ordinarily the Eq Input). The Measurement microphone is selected from the SIM-2403 Interface Network. All Frequency response data are of the Result type. The Measurement microphone should not be placed closer to the sound source than the Reference microphone, because you will not be able to set the Internal Delay Time if the Measurement mic signal arrives before the Reference mic signal.

Applications:

- Perform a fast diagnostic test of measurement microphones.
- Perform measurements without the use of loudspeakers or other electrical devices. An example of this is measuring the Frequency response between the stage and the audience areas of a symphonic concert hall.
- Analyze the response of different microphones compared to a reference microphone.

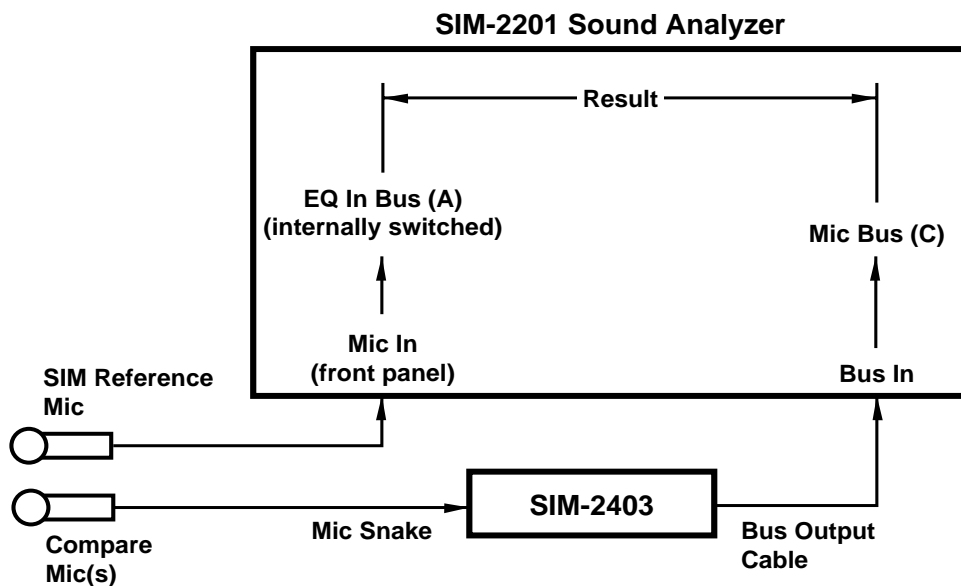

Figure 52 — Procedure: Mic Compare Block Diagram

Microphone evaluation

This type of Mic Compare measurement is dependent upon the quality of the Reference microphone (the one plugged into the front panel). Therefore, it is important that only the highest quality mics be used, such as the B & K 4007 SIM Reference Microphone, which is selected and matched by Brüel and Kjaer for Meyer Sound. The ideal Frequency response between the mics would occur if the mics were capable of occupying the same position. Because this is obviously not possible, it is also important that care be exercised to prevent the mics from reflecting into each other or from being so far apart as to be in different acoustic environments.

Acoustic response measurements without speakers

This type of Mic Compare measurement is dependent upon the placement of the reference microphone (the one plugged into the front panel). Therefore, it is important that the Reference mic be placed in a position that is known to have particular type of response. The Frequency response between the mics shows the difference between the two positions. The microphones should be of the same type with a matched response, so that the Frequency response is limited to the difference in the acoustic responses at the different positions.

Use the Microphone Setup Panel to label the microphones' types and positions. Use the Branch Setup Panel to define the Branch names and assign one mic to each of them. The Eq Input and Eq Output channels are not used in the Mic Compare Procedure, and their settings are irrelevant.

To make and store Mic Compare measurements, follow these steps:

- 1) Select the **mlc Compare** Procedure.
- 2) **Measure: Delay finder** — Set the Internal Delay Time to compensate for the propagation delay between microphones.
- 3) Select a Branch which owns the desired Microphone channel.
- 4) **Measure: Frequency response.**
- 5) When the measurement is complete, you may store it using the **Data: Store** (mlc Compare) command.

3.3.8 Show

SIM System II is designed to measure sound systems with an audience present, so certain functions that could disrupt a performance are disabled in Show Procedure.

During show Procedure:

- The Generator is disabled.
- All speakers must be on, so speaker muting is disabled.
- Only the Post Process and Quit Procedures can be selected during the show.

Because of these assumptions, it is necessary to make absolutely sure that you are ready to move into the Show Procedure. All steps that precede the Show Procedure should be performed before moving into the Show Procedure.

Note for v. 2.3 Stereo users: The Eq out signal passes through an internal relay that is capable of muting the speaker sends. Once you have entered Procedure: Show, there are no commands in the software that can mute the speakers. If the SIM-2201 Sound Analyzer loses power the relays will not mute and signal will continue to flow as before. However, it is possible that an inadvertent hardware error could cause the mute relay to close. For a true hardwire parallel connection as implemented in the SIM-2403 Interface Network, you should insert a "Y" cable in the path at the "Eq Output" cable in place of the "To Amps" cable.

Note for v. 2.3 Multi-channel users: When measuring during a concert it is strongly advised that the system be set into its “Safe” configuration. The “System Muting” configuration of the SIM-2403 Interface Network, which is used during the alignment phase to mute and adjust levels carries a risk if used during a show. To prevent the possibility of inadvertent speaker muting from a loss of power or software control, move the System Snake on the rear of the SIM-2403 Interface Network to the “System Safe” position. When re-patching the System snake, it is recommended that all amplifiers be temporarily turned off.

If the speaker level controls of the SIM-2403 Interface Network have been moved from the unity gain position, they must be re-adjusted as follows before patching to the “Safe” position:

- 1) Select **Procedure: Single System** and **Measure: Frequency response**.
- 2) For each speaker system that is not already at unity:
 - **Data: Store** and **Data: Recall** (or **F5**).
 - Readjust speaker level on SIM-2403 Interface Network to unity (fully CW).
 - Adjust speaker system level at some point post-Eq output controllers or amplifiers) until the live trace overlays the stored trace.

When this task has been completed for all systems, patch the System Snake to the System “Safe” position.

When this patch has been made, the green “Safe” LED on the front panel of the SIM-2403 Interface Network will be illuminated. The SIM-2201 could now be powered down without risk to the path of the sound reinforcement signal. It is also recommended that the Source Output be unpatched from the system console. Select **Procedure: Show**.

3.3.9 pOst process

The Post Process Procedure enables displaying multiple memory traces. As the name connotes, no new data are taken. All data are of the Frequency response type, and are obtained from the memory array.

The color designation closely resembles those of the Frequency response screen.

3.3.10 Quit

Select **Procedure Quit** to exit the program. Before exiting, you will be prompted to save the Setup and any data to disk. The Generator is turned off and all speakers are unmuted.

3.3.11 Speaker Menu

The Speaker Menu enables remote switching of speaker systems from the keyboard. This has several advantages over manual control:

- No additional personnel are needed at the amplifier racks to control speaker muting. This saves time and greatly reduces the risk of error.
- The control is ahead of the amp racks and crossovers, allowing speaker systems to be muted from a single point. This is particularly advantageous with systems having multiple speakers and amplifiers fed from a single equalizer, as such systems can otherwise require entire banks of amplifiers be switched off and on.
- The SIM-2201 Sound Analyzer tracks the speaker system status. This allows the speaker control function to work in conjunction with the Procedure Menu to assure measurement of the proper speaker combinations. Additionally, information about which speakers are on is attached to measurement data which is stored and saved to disk, and is displayed on the screen for both live and memory data.

-
- Because muting occurs after the Eq outputs, speakers may be muted after storing the Room+speaker Frequency responses, and equalizers may be adjusted while being viewed against the stored Room+speaker data. This is very advantageous in situations requiring an absolute minimum amount of disturbance.

Speaker switching is closely tied to the present Procedure. Each Procedure has a different strategy for selecting speakers:

- **Pretest** — All speakers are turned on, and may not be muted.
- **Single System** — Only the present Branch's speaker is selected. All others are muted.
- **Lobe Study** — Any combination of speakers may be selected except the present Branch's.
- **External Delay** — Any single speaker may be selected except the present Branch's.
- **Combined Systems** — Any combination of speakers may be selected; however, the present Branch's speaker is always on, and cannot be muted.
- **Mic Eq, Mic Compare** — Any combination of speakers may be selected.
- **Show, Quit** — All speakers are turned on, and may not be muted.

Speakers switching also follows Branch changes, making it unnecessary to do speaker switching when a different Branch is selected.

The speaker Menu allows individual manual switching of speakers, and provides four options:

- **all Off** — Mutes all speaker systems. Allows system equalization when when it is important to minimize the use of test signals in a venue.
- **Select** — A Button Menu providing individual speaker on/off switching.
- **Enable** — Enables default switching for speakers.
- **All on** — Turns on all speakers.

Select

The Select button Menu provides switching for up to eight speakers controlled by one SIM-2403 Interface Network. Speakers which are on are represented by green buttons, those off by red. The eight buttons are also labeled with the speaker Names entered on the Speaker Setup Panel.

Press number number keys 1-8 or F1-F8 to toggle individual speakers on/off. To select speakers at a different SIM-2403 address, press PgUp/PgDn. Since SIM System II addresses up to eight SIM-2403's, up to sixty-four speaker systems may be switched.

During certain Procedures, some speakers may be unavailable for switching, in which case the button and speaker Name will be greyed out and the button will not toggle the speaker. For example, in Lobe Study, the present Branch's speaker is disabled.

Enable

Enable provides a quick way to pick a default ("usual") set of speakers to turn on, depending on the present Procedure and Branch.

Selecting **Enable** in Single System Procedure will turn on the present Branch's speaker and mute all others. As you step through the Branches, each Branch's speaker will turn on as the rest are muted.

Selecting **Enable** in Combined Systems Procedure will automatically turn on the present Branch's speaker, and any other speakers that were previously selected in combined systems or Lobe Study.

Selecting **Enable** in Lobe Study Procedure will automatically turn off the present Branch's speaker, and turn on any other speakers that were previously selected in Combined Systems or Lobe Study.

Select and Enable

The Speaker Select menu remembers which speakers were on when the Procedure changes. When multiple speakers are selected during Combined Systems and Lobe Study, the selection is maintained in memory. If you select Single System (one speaker only) and then return to Combined Systems or Lobe Study, the same speaker selection will return. This is best explained by an example.

In this example, we will assume that Branch 1 controls Speaker 1, Branch 2 controls Speaker 2, etc. (the default Setup).

- 1) Select Branch 1.
- 2) In **Combined Systems** Procedure, select Speakers 1-4. All others should be off.
- 3) Select **Single System** Procedure, **Speaker: Enable**. Speaker 1 will be on; all others will be muted. As you step through the Branches, each Branch's Speaker will turn on as the rest are muted.
- 4) Now return to Branch 1, and select **Combined Systems, Speaker: Enable**. Notice that Speakers 1-4 are now selected, as they were before you entered the Single System Procedure.
- 5) Select **Lobe Study** Procedure, **Speaker: Enable**. Notice that Branch 1's speaker is now off, while Speakers 2-4 are still on. As you step through the Branches, each Branch's speaker will muted, and the remaining three will be on.
- 6) If you then select **Single System** Procedure and return to **Lobe Study**, the same three speakers will still be selected.

Summary

The selection of multiple speakers made in Lobe Study, Combined Systems (and Mic Eq) is remembered by the system when the Procedure is changed. Once a set of speakers has been selected from the **Speaker: Select** Menu, **Speaker: Enable** will turn on the appropriate speakers based on the current Procedure and Branch.

3.3.13 Procedure Menu Reference Guide

Procedure	Measure	Speaker	Trace Offset	Generator
Pretest*	Spectrum†	All On†	No†	Off* 1 kHz Sine Var Sine Noise Pulse
Single Sys	Spectrum* Delay finder Freq. Response Feedback find	All Off Enable*	Yes†	Off* 1 kHz Sine Var Sine Noise Pulse
External Delay	Spectrum Delay finder*	All Off Select Ref* Enable	No†	Off* Noise Pulse
Lobe Study	Spectrum* Delay finder Freq. Response Feedback find	All Off Select Enable*	No†	Off* 1 kHz Sine Var Sine Noise Pulse
Comb Systems	Spectrum* Delay finder Freq. Response Feedback find	All Off Select* Enable All On	No†	Off* 1 kHz Sine Var Sine Noise Pulse
Mic EQ	Spectrum* Delay finder Freq. Response	All Off* Select Enable All On	Yes†	Off* 1 kHz Sine Var Sine Noise Pulse
Mic Compare	Spectrum* Delay finder Freq. Response	All Off Select* Enable All On	Yes†	Off* 1 kHz Sine Var Sine Noise Pulse
Show	Spectrum* Delay finder Freq. Response Feedback find	All On†	Yes†	Off†
Post process	Freq. Response	All On†	Yes or No	Off†

* Default (Original Setting)

† Only Available Setting or not user adjustable

Section 4: Service

In the event that a malfunction occurs in the SIM hardware, call Meyer Sound as soon as possible. The system is covered by a limited one-year warranty.

Failure types

There are three types of failure modes:

- Non-fatal hardware failure modes that may be circumvented temporarily in the field.
- Fatal hardware failure modes that are user serviceable
- Fatal hardware failure modes that require factory service and calibration.

4.1 Non-fatal failures

4.1.1 Power supply surge protection. The power supply contains current surge protection circuits designed to limit in-rush current. It is possible that during turn-on, this circuit will engage. The system will appear to be totally dead although anything plugged onto the courtesy outlet, such as the monitor, may function normally. This is most likely to occur in the event of an immediate re-powering after shut down. If this should occur, simply wait at least fifteen seconds and try again. The system should power up normally.

4.1.2 Hard drive dead or missing <HDD Failure>

Power down. Remove hard drive cartridge. Insert floppy disk of the program that you wish to run and reboot. Bootup will take approximately two minutes. The floppy disk may be removed after boot-up so that data can be saved to another disk. Do not attempt to save data to hard drive.

4.1.3 Floppy drive dead <FDD Failure>

No immediate action required. Do not attempt to save data to floppy drive.

4.1.4 BIOS battery failure <CMOS Memory Mismatch>

The BIOS chip contains basic instructions for the computer such as disk drive configurations, memory types and keyboard parameters. The BIOS instructions are kept in CMOS memory by a lithium battery while the system is turned off. If this battery fails, the system will no longer be capable of booting up normally. To fully remedy the problem will require battery replacement and a resetting of the BIOS. In the short term, the BIOS may be reprogrammed on-site. As an emergency backup, you will find the BIOS instruction set printed on the bottom of the keyboard. Follow the BIOS instructions. The system will retain the BIOS settings until powered down. Until the battery is replaced, the BIOS will need to be reset each time the system is powered up.

4.2 SIM 2201 BIOS Setup

Accessing BIOS Setup Program

- 1) With the removable hard drive installed, reboot the SIM 2201 by turning the power on or pressing the front-panel Reset key.
- 2) The system will begin running its POST (Power On Self Test) routines, starting with a memory check. Following the memory check, the system will prompt you to run the BIOS Setup Program.
- 3) Press **<F1>** in response to the prompt.
The BIOS Setup Program will run, and a menu of options will appear.
- 4) Press **<ENTER>** to select the first option, Standard CMOS Setup.

Navigating and Selecting Values

The keys used to navigate within the Setup Program and select values are:

ESC — Exit to previous screen.

Arrow keys — Move Cursor to desired location.

PG UP, PG DN — Select the values for the highlighted item. PG UP decrements the value (in the case of numerical values like the time of day), and PG DN increments it.

F1 — Display help screen for the highlighted item.

F5 — Retrieves the value that the highlighted item was set to at the start of the editing session.

F10 — Saves all changes and exits the BIOS Setup Program.

Standard CMOS Setup Values

- 1) Press any key in response to the initial warning prompt. The system BIOS will show these values:

Base Mem = 640 kB

Ext. Memory = 15104 kB or 15360 kB (7808 kB for machines with serial numbers below D920011)

- 2) Where necessary, edit the values shown in the Standard CMOS Setup display to be as shown below:

Hard disk C: type	:	User Type	Cyln	Head	WPcom	LZone	Sect	Size
		47	1024	6	0	1024	38	114MB

(You will have to type in the above values manually)

Hard disk D: type	:	Not Installed
Floppy drive A:	:	1.44 MB, 3 1/2"
Floppy drive B:	:	Not Installed
Primary Display	:	VGA/PGA/EGA
Keyboard	:	Installed

- 3) Press **<ESC>** to return to the main menu page. Use the down arrow key to select Advanced CMOS Setup, then press **<ENTER>**.

Advanced CMOS Setup Values

- 1) Press any key in response to the initial warning prompt.
- 2) Where necessary, edit the values shown in the Advanced CMOS Setup display to be as shown below:

Typematic Rate Programming	:	Disabled
----------------------------	---	----------

Typematic Rate Delay (msec)	: 250
Typematic Rate (Chars/sec)	: 10.0
Above 1MB Memory Test	: Enabled
Memory Test Tick Sound	: Disabled
Memory Parity Error Check	: Enabled
Hit <ESC> Message Display	: Disabled
Hard Disk TYPE 47 RAM Area	: 0:300
Wait for <F1> if Any Error	: Disabled
System Boot Up Num Lock	: Off
Weitek Processor	: Absent
Floppy Drive Seek At Boot	: Enabled
System Boot Up Sequence	: A:,C:
System Boot Up CPU Speed	: High
Password Checking Option	: Setup
Shadow RAM option	: Enabled

- 3) Press <ESC> to return to the main menu page. Use the down arrow key to select Advanced Chipset Setup, then press <ENTER>.

Advanced Chipset Setup Values

- 1) Press any key in response to the initial warning prompt.
- 2) Where necessary, edit the values shown in the Advanced CMOS Setup display to be as shown below:

8-bit DMA Wait states	: 2 W/S
16-bit DMA Wait states	: 2 W/S
DMA Clock	: SCLK/2
Command Delay, 8-bit Cycle	: No
Command Delay, 16-bit Cycle	: No
8-bit I/O Wait States	: 4 W/S
16-bit I/O Wait States	: 0 W/S

- 3) Press <ESC> to return to the main menu page. Use the down arrow key to select Auto Configuration with BIOS Defaults, then press <ENTER>.

Auto Configuration with BIOS Defaults

- 1) Answer the prompt "Load BIOS Setup Default Values from ROM Table (Y/N)?" by pressing <N> and <ENTER>.
- 2) Press <ESC> to return to the main menu page. Use the down arrow key to select Auto Configuration with Power-On Defaults, then press <ENTER>.

Auto Configuration with Power-On Defaults

- 1) Answer the prompt "Load Power-On Default Values from ROM Table (Y/N)?" by pressing <N> and <ENTER>.
- 2) **Press <ESC> to return to the main menu page. Saving the Changes**
 - 1) Use the down arrow key to select Write to CMOS and Exit, then press <ENTER>.
 - 2) Answer the prompt "Write to CMOS and Exit (Y/N)?" by pressing <Y> and <ENTER>.

The BIOS is now configured.

The SIM software will run from the removeable hard drive. *Note that, until the backup battery is replaced, you will have to reconfigure the BIOS after each time that you turn the SIM 2201 off. Pressing the front-panel reset key will not affect the BIOS, however.*

4.3 User-Serviceable

All user serviceable repairs require the removal of the top cover (8 screws).

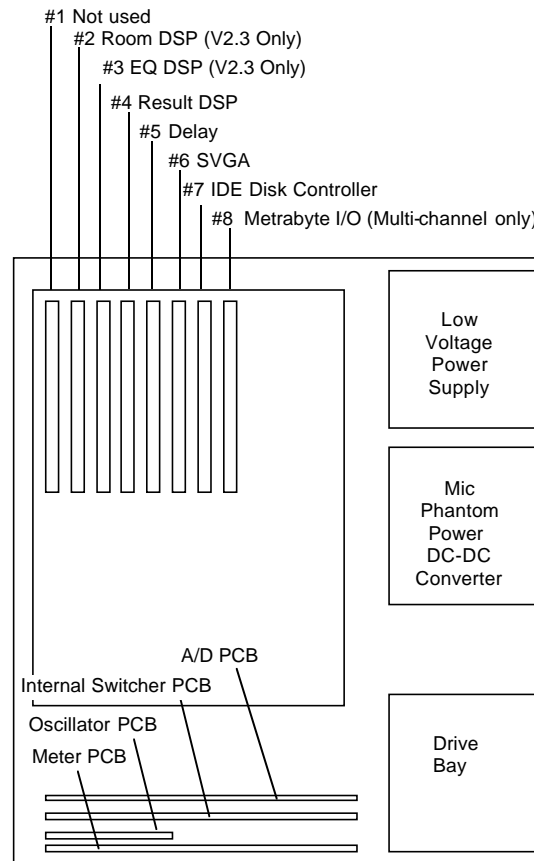

Figure 53 — SIM-2201 PCB layout

4.3.1 SVGA

Remove hold down bracket from top of card cage (4 screws). Remove screws (4) from rear panel and fold down. Note the two plastic fasteners that hold the bottom of the Power Supply. The SVGA card is located in slot 6 of the motherboard PCB. Remove SVGA connector from rear bracket (2 screws). Remove screw on bracket card. Replace the SVGA card.

4.3.2 IDE Disk controller

Remove hold down bracket from top of card cage (4 screws). Remove screws (4) from rear panel and fold down. Note the two plastic fasteners that hold the bottom of the Power Supply. The IDE card is located in slot 7 of the motherboard PCB. Remove serial and mouse port connectors from rear bracket (4 screws). Remove floppy, hard drive, drive LED indicator connectors from component side. Remove screw on bracket. Replace the IDE card.

4.3.3 I/O Card

Remove hold down bracket from top of card cage (4 screws). Remove screws (4) from rear panel and fold down. Note the two plastic fasteners that hold the bottom of the Power Supply. The I/O card is located in slot 8 of the motherboard PCB. Remove D25 connector from rear bracket (2 screws). Remove screw on bracket card. Replace the I/O card.

4.3.4 DSP Card

Remove hold down bracket from top of card cage (4 screws). The DSP cards are located in slots 2,3 and 4 of the motherboard PCB. Remove the ribbon connector from that connects to the Delay PCB (Slot 5). The ribbon connectors are specific lengths to prevent connection errors. To remove the card from slot 4 will require the removal of the other DSP boards as well. Be careful not to bend the pins. Remove screw on bracket card. Set the replacement DSP card address according to Figure 56, then install it. Ensure proper connection of the ribbon cables.

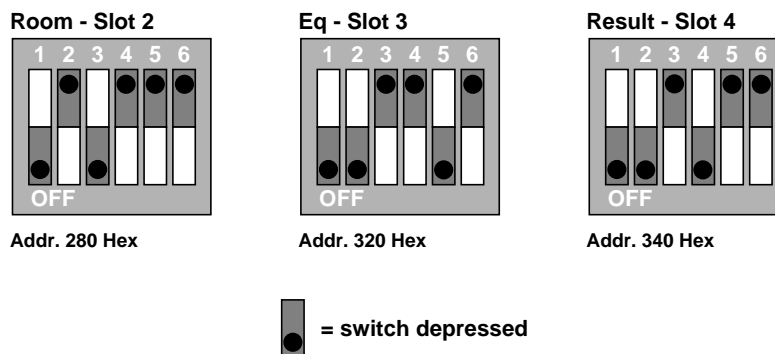

Figure 54 — Setting the Addresses of DSP cards for the SIM-2201

4.3.5 Motherboard

Remove all PC bus cards as above. Remove motherboard power supply connections. Remove battery connection. Use a needlenose pliers or flathead screwdriver to unlock the plastic fasteners and ease the motherboard over each fastener. It is easiest to work your way up from the rear. Remove the SIMM's (see below) and move them to the new motherboard. Place board into conductive plastic bag. Install new motherboard.

4.3.6 SIMMs (Single In-line Memory Modules.)

There are 4 SIMMs each containing 4 Mbytes of memory. Remove by unlocking the both of the clips and sliding out. It is necessary to remove them in order from last to first and insert them in the reverse order.

4.3.7 Power Supply

Remove screws (4) from rear panel and fold down. Note the two plastic fasteners that hold the bottom of the Power Supply. Unscrew the power supply from the rear panel (4 Screws). Clip away wire tie on power supply output cables and disconnect. Each of the cables are identical therefore it is not important to keep track of their routing. Replace the Power Supply. Take care to insure that cables are connected to:

- DC Converter PCB
- Fans (2)
- Hard drive
- Floppy Drive

Tie wrap cables as before.

4.3.8 DC Converter PCB

Remove screws from DC Converter PCB. Remove input and output cabling from PCB. Replace and reconnect.

4.3.9 Floppy drive

Remove top cover (8 screws). Remove power and signal connections from the hard and floppy drives. Note orientation of signal connectors. Remove 4 screws from the bottom panel that hold the drive bay. Lift drive bay and remove. Unscrew drive bracket (8 screws) and remove. Replace and reconnect.

4.3.10 Hard Drive Receptacle

Same as floppy drive (above).

4.3.11 Hard drive Cartridge

Remove and replace.

4.4 Rear panel service

- 1) Remove top cover
- 2) Remove power supply screws (4)
- 3) Remove rear panel screws
- 4) Fold down panel

4.5 Front panel service

- 1) Remove top cover
- 2) Front panel screws on chassis side and bottom. (5)
- 3) Disconnect front panel cabling
- 4) Fold down panel

4.6 Factory service required

The user serviceable failures are limited primarily to the replacement of computer PCB's. Any failures in the audio signal path will require the system to be returned to the factory for recalibration. This would include:

- 1) Audio channel failure
- 2) Excess noise or distortion
- 3) Switching /routing errors

Section 5 — Appendices

A. Connection Diagrams

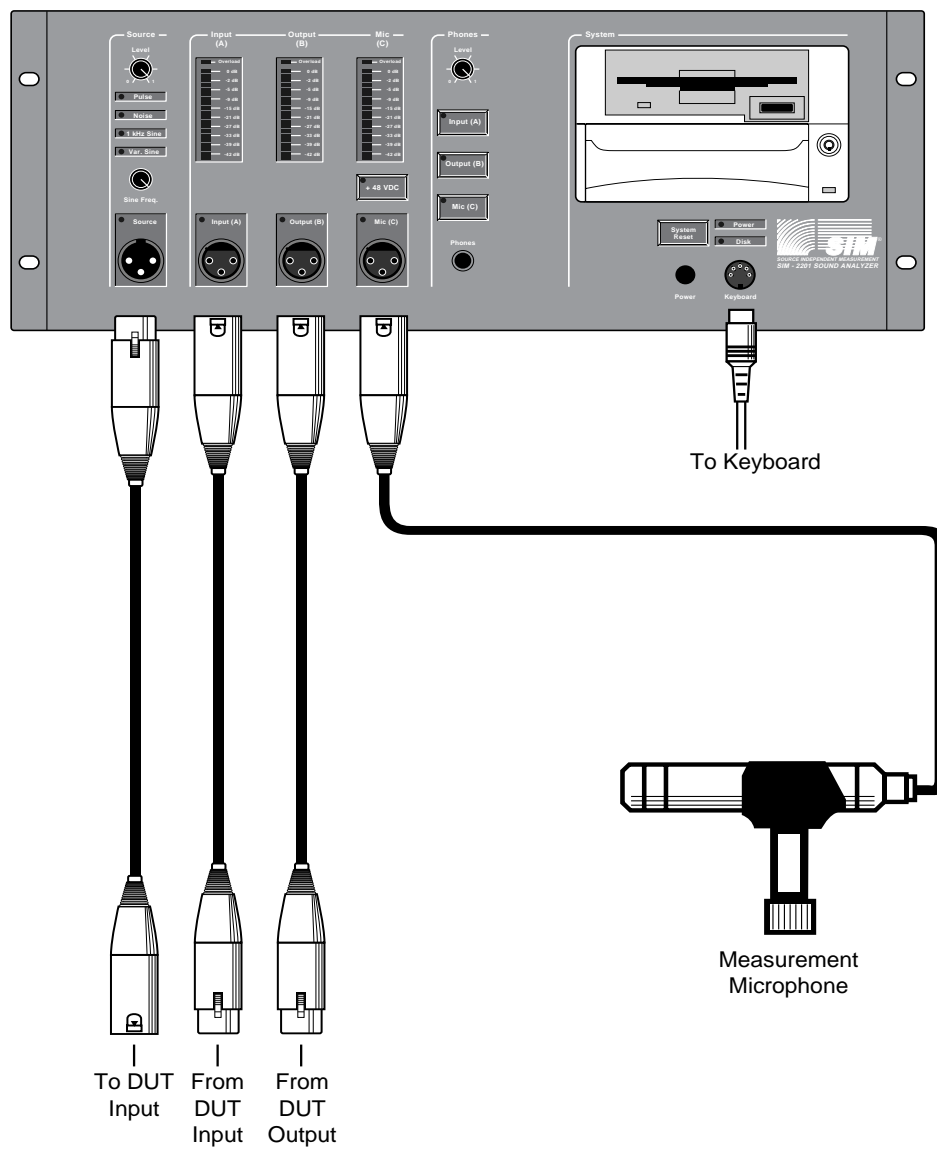

Figure 55 — v. 2.0 Lab Connections

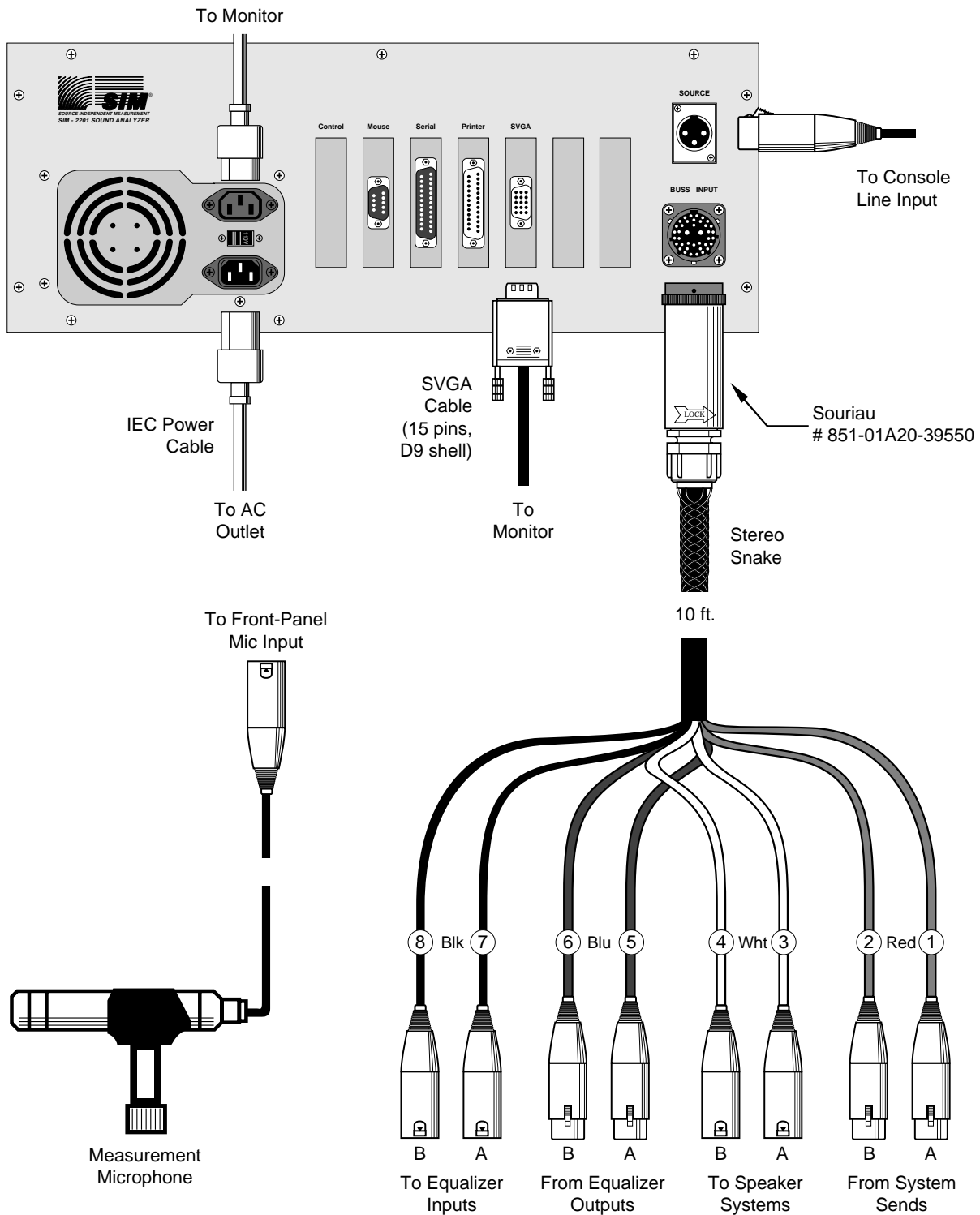

Figure 56 — v. 2.3 Stereo Connections

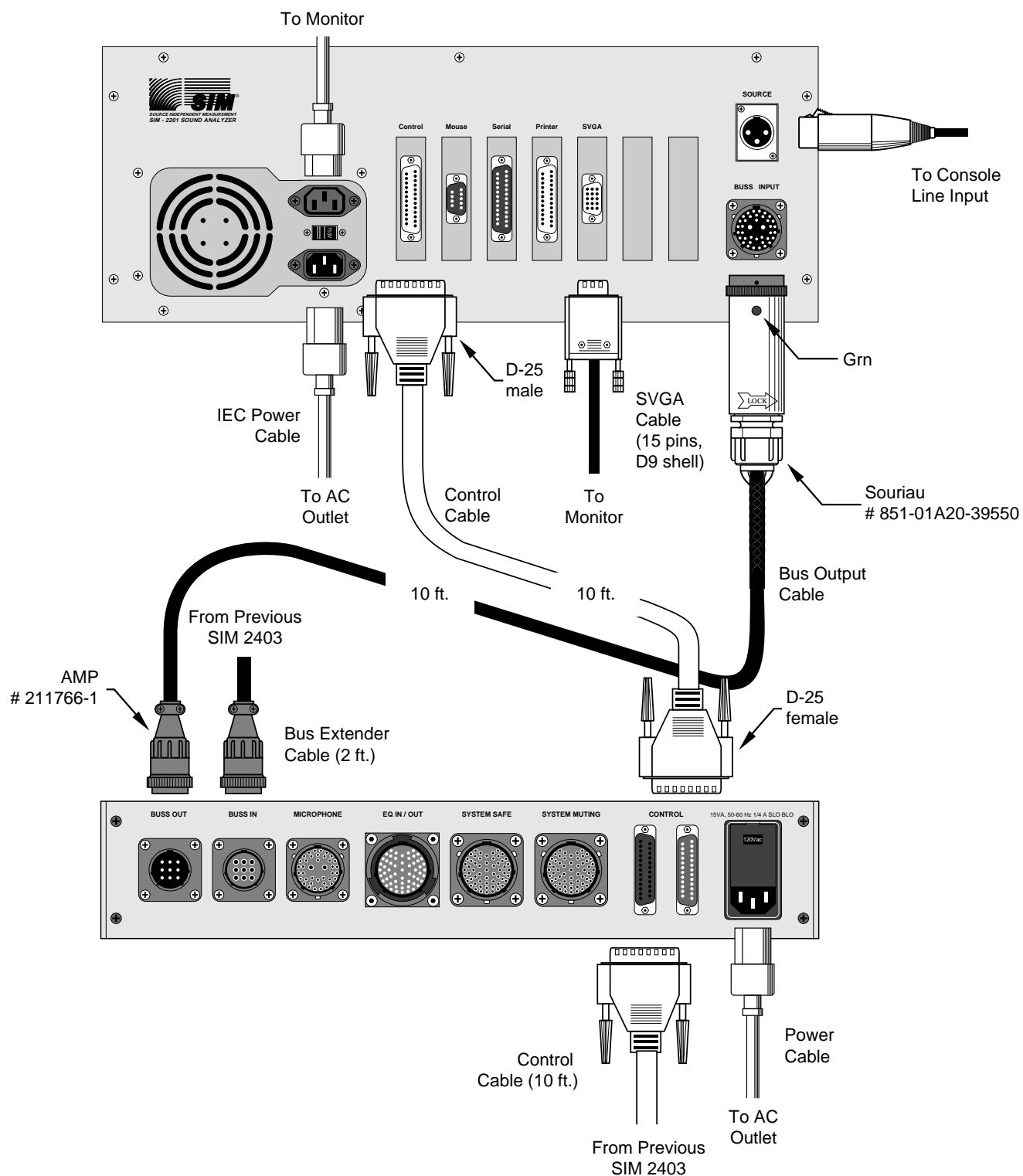

Figure 57 — v. 2.3 Multi-Channel Connections Between the SIM-2201 Sound Analyzer and SIM-2403 Interface Network

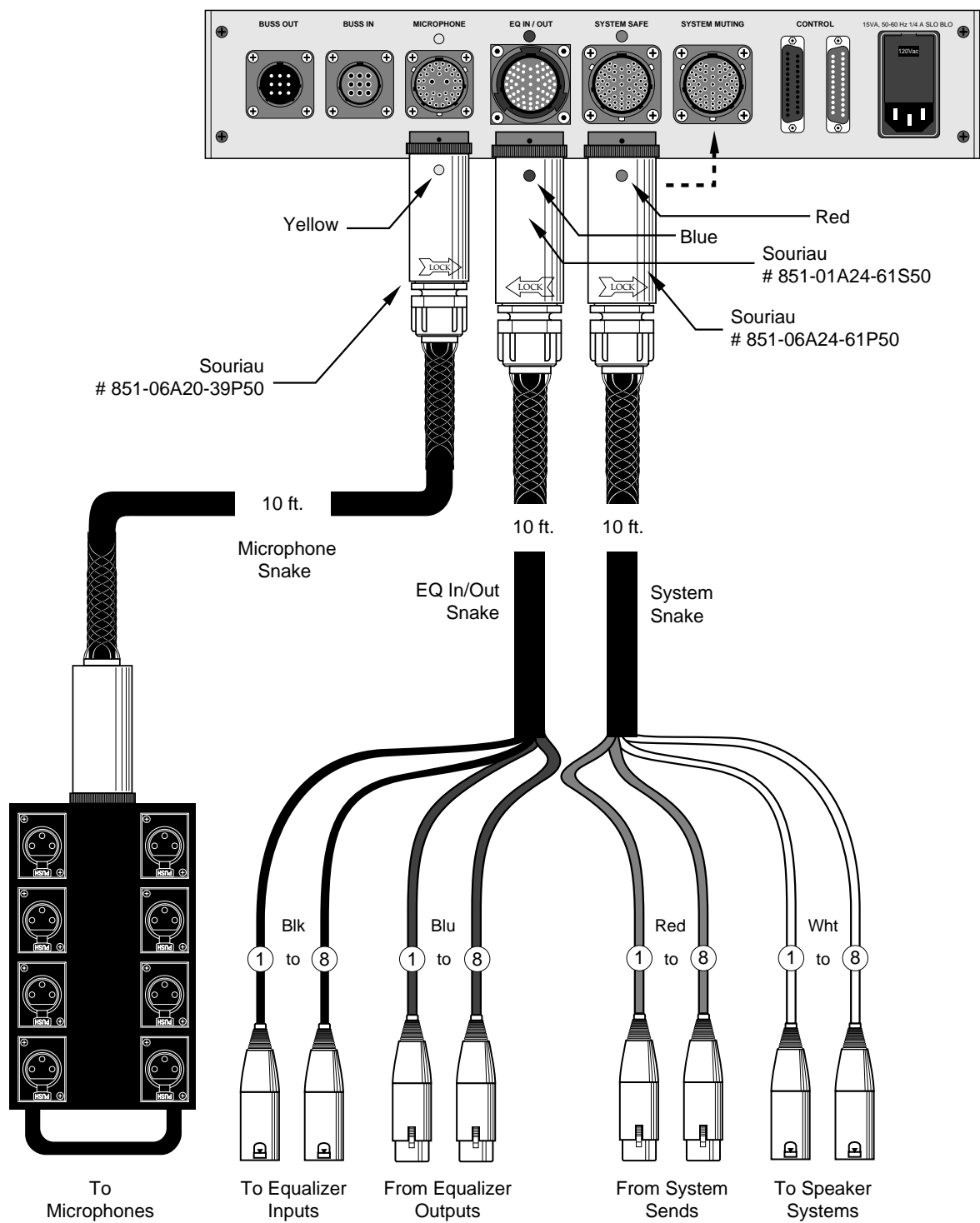

Figure 68 — Connections Between the SIM-2403 Interface Network and the PA System

B. Cable Pinout Charts

Mic Snake Pinout Chart			39 pin			Channel
Pair #	Pin 3+ Color	Pin 2- Color	Pin 3 +	Pin 2-	Pin1(C)	
1	Black	Red	n	P	q	Mic 1
2	Black	White	A	W	x	Mic 2
3	Black	Green	f	N	P	Mic 3
4	Black	Blue	e	L	M	Mic 4
5	Black	Yellow	d	J	K	Mic 5
6	Black	Brown	c	G	H	Mic 6
7	Black	Orange	b	E	F	Mic 7
8	Red	White	a	D	Z	Mic 8
9	Red	Green	B	C	Y	Spare

Buss Output Pinout Chart			39 pin			Channel	CPC
Pair #	Pin 3+ Color	Pin 2- Color	Pin 3 +	Pin 2-	Pin1(C)		Pins 3-2-1
1	Black	Red	n	P	q	EQ In Buss	3-2-1
2							
3							
4						EQ Out Buss	6-5-4
5	Black	Yellow	d	J	K		
6							
7						Mic Buss	9-8-7
8							
9	Red	Green	B	C	Y		

Stereo Snake Pinout Chart			39 pin			Channel
Pair #	Pin 3+ Color	Pin 2- Color	Pin 3 +	Pin 2-	Pin1(C)	
1	Black	Red	n	P	q	Console 1
2	Black	White	A	W	x	Console 2
3	Black	Green	f	N	P	To Amp 1
4	Black	Blue	e	L	M	To Amp 2
5	Black	Yellow	d	J	K	EQ Out 1
6	Black	Brown	c	G	H	EQ Out 2
7	Black	Orange	b	E	F	EQ In 1
8	Red	White	a	D	Z	EQ In 2
9	Red	Green	B	C	Y	Spare

Buss Extender Pinout Chart			9 pin			Channel
Pair #	Pin 3+ Color	Pin 2- Color	Pin 3 +	Pin 2-	Pin1(C)	
1	Black	Red	3	2	1	Eq In Buss
2	Black	White	6	5	4	Eq Out Buss
3	Black	Green	9	8	7	Mic Buss
4	Black	Blue				
5	Black	Yellow				
6	Black	Brown				

System Snake Pinout Chart			<i>61 pin</i>			<i>Channel</i>
<i>Pair #</i>	<i>Pin 3+ Color</i>	<i>Pin 2- Color</i>	<i>Pin 3 +</i>	<i>Pin 2-</i>	<i>Pin1(C)</i>	
1	Black	Red	HH	JJ	NN	Console 1
2	Black	White	KK	MM	PP	Console 2
3	Black	Green	AA	BB	CC	Console 3
4	Black	Blue	FF	s	W	Console 4
5	Black	Yellow	EE	r	V	Console 5
6	Black	Brown	D	e	x	Console 6
7	Black	Orange	E	f	y	Console 7
8	Red	White	DD	q	U	Console 8
9	Red	Green	P	S	T	To Amp 1
10	Red	Blue	N	P	R	To Amp 2
11	Red	Yellow	k	m	n	To Amp 3
12	Red	Brown	K	L	M	To Amp 4
13	Red	Orange	i	J	j	To Amp 5
14	Green	White	G	H	h	To Amp 6
15	Green	Blue	F	g	z	To Amp 7
16	Green	Yellow	C	d	w	To Amp 8

EQ Snake Pinout Chart			<i>61 pin</i>			<i>Channel</i>
<i>Pair #</i>	<i>Pin 3+ Color</i>	<i>Pin 2- Color</i>	<i>Pin 3 +</i>	<i>Pin 2-</i>	<i>Pin1(C)</i>	
1	Black	Red	HH	JJ	NN	EQ In 1
2	Black	White	KK	MM	PP	EQ In 2
3	Black	Green	AA	BB	CC	EQ In 3
4	Black	Blue	FF	s	W	EQ In 4
5	Black	Yellow	EE	r	V	EQ In 5
6	Black	Brown	D	e	x	EQ In 6
7	Black	Orange	E	f	y	EQ In 7
8	Red	White	DD	q	U	EQ In 8
9	Red	Green	P	S	T	EQ Out 1
10	Red	Blue	N	P	R	EQ Out 2
11	Red	Yellow	k	m	n	EQ Out 3
12	Red	Brown	K	L	M	EQ Out 4
13	Red	Orange	i	J	j	EQ Out 5
14	Green	White	G	H	h	EQ Out 6
15	Green	Blue	F	g	z	EQ Out 7
16	Green	Yellow	C	d	w	EQ Out 8

C. ISO™ Input (Channels A and B)

Signal Source Configuration	Wiring of SIM-2201 Input			Polarity	Comments
	Pin 1	Pin 2	Pin 3		
Transformer or Push-Pull Drive	n/c	-	+	+	Best CMRR, lowest hum
	n/c	+	-	-	
	C	-	+	+	
	C	+	-	-	
	-	-	+	+	
	-	+	-	-	
	-	n/c	+	+	
	-	+	n/c	-	
Single-ended Drive	n/c	C	+	+	Best performance
	n/c	+	C	-	
	C	C	+	+	
	C	+	C	-	
	C	n/c	+	+	
	+	n/c	C	-	
	C	+	n/c	-	
	+	C	n/c	+	

Key:

+ Signal high
 - Signal low
 C Common
 n/c No connection

Figure 59 — ISO™ Input Connection Truth Table

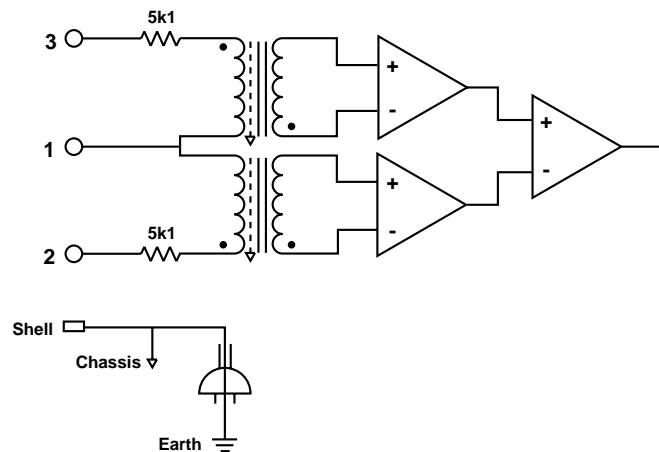

Figure 60 — ISO™ Input Circuit Configuration (patented)

D. ASCII Data File Example

Data: Save Ascii saves to disk a file containing the current measurement data in Ascii format. This allows porting SIM System II measurement data into other programs for post-analysis. Below is an example of an Ascii data file, including header and data for one Group.

```

ASCII 101                               format
1                                         Branch number
Left                                     Branch name
Venue
Engineer's name
Artist
Mon Mar 15 14:01:47 1993                date/time
0.00                                     Branch delay in ms
0.00                                     trace offset in dB
-60                                      transfer function Amplitude threshold in dB
4                                        number of room/result averages
0                                        Group number 0-7
1                                        data flag: 0 = no data, 1 = data in this Group
2                                        Procedure number: 2 = single sys
0                                        Branch Eq address
1                                        speakers on
0                                        Branch mic address
1                                        Branch mic channel
4                                        Group number of room/result averages
0                                        Group average type 0 = vector 1= RMS
1                                        Group avg sum type 0 = none, 1 = cycle, 2 = accumulate
-60                                      Group tranfer function Amplitude threshold dB
60                                       Group Coherence threshold
732222051                               Group time/date code
0.00                                     Group delay time
0.00                                     Group trace offset in dB
Room
Frequency  Valid    Real          Imag          Valid  Coher
7.629395   1      -8.300267e-001  -5.306641e-001  1      8.836815e-001
9.155273   1      1.866838e-001  9.649961e-001  1      9.898558e-001
10.68115   1      2.940286e-001  8.383676e-001  1      9.881984e-001
12.20703   1      5.385644e-001  7.546250e-001  1      9.863895e-001
13.73291   1      7.860123e-001  7.340807e-001  1      8.880601e-001
15.25879   0      0.000000e+000  0.000000e+000  1      5.797662e-001
16.78467   1      1.048826e+000  1.923313e-001  1      9.252884e-001
18.31055   1      5.663163e-001  8.439134e-001  1      9.786824e-001
19.83643   1      -6.006017e-001  3.571306e-001  1      9.770353e-001
21.36230   1      -1.691158e-001  9.381513e-002  1      7.763644e-001
22.88818   1      6.022303e-001  -4.340758e-001  1      7.807058e-001
24.41406   1      2.733261e-001  -7.722968e-001  1      7.033427e-001
25.93994   1      1.138830e+000  6.943674e-001  1      9.858620e-001
27.46582   1      -1.405302e+000  1.034664e+000  1      9.872375e-001
28.99170   1      5.814646e-001  -1.970626e+000  1      9.884516e-001

```

30.51758	1	-4.983518e-001	2.200281e+000	1	9.894276e-001
32.04346	1	-2.167822e+000	-1.481548e+000	1	8.720998e-001
33.56934	1	7.843834e-001	1.618317e+000	1	8.474381e-001
35.09521	1	5.120405e-001	2.049959e+000	1	9.064807e-001
36.62109	1	1.871092e+000	8.288648e-001	1	9.909747e-001
38.14697	1	1.193832e-001	-1.862051e+000	1	8.526236e-001
39.67285	1	-1.274758e+000	-6.395878e-001	1	9.784470e-001
41.19873	1	5.897506e-001	-5.475165e-001	1	7.539119e-001
42.72461	1	-4.834534e-001	-4.368375e-001	1	8.460298e-001
44.25049	1	-2.227576e-001	-1.675267e-001	1	9.889500e-001
45.77637	1	-2.797758e-001	4.639234e-001	1	9.411441e-001
47.30225	1	7.594414e-001	3.534277e-001	1	6.861296e-001
.					
.					
.					
22265.63	1	3.145627e+000	3.499455e+000	1	9.387659e-001
22656.25	1	4.933742e+000	3.295355e-001	1	8.691644e-001
1/Eq					
frequency	Valid	Real	Imag	Valid	Coher
7.629395	0	0.000000e+000	0.000000e+000	1	8.074194e-001
9.155273	1	-1.893269e-001	9.821295e-001	1	9.962614e-001
10.68115	1	1.884563e-001	8.887328e-001	1	9.961203e-001
.					
.					
.					
21875.00	1	1.898098e+000	-3.587669e+000	1	9.723826e-001
22265.63	1	-6.710988e-001	-4.724140e+000	1	9.751457e-001
22656.25	0	0.000000e+000	0.000000e+000	1	8.210352e-001
Result					
frequency	Valid	Real	Imag	Valid	Coher
7.629395	1	1.104442e+000	1.433564e-002	1	9.155470e-001
9.155273	1	8.867108e-001	-6.845629e-001	1	8.042046e-001
10.68115	1	4.380753e-001	7.903274e-001	1	9.926020e-001
.					
.					
.					
21875.00	1	1.732928e-001	-3.264641e+000	1	7.997649e-001
22265.63	1	2.270072e+000	-2.904307e+000	1	6.258271e-001
22656.25	1	-2.630178e+000	4.097490e+000	1	9.592857e-001
Notepad line #1					
Notepad line #2					
Notepad line #3					

E. Shortcut Keys

v. 2.0 Lab

Data:

F5 Freeze Frequency response trace and place in memory buffer
F6 Data: Clear
F10 Hides Live or Memory Traces (Toggle)

Setup:

= or + Setup: trace Offset up 1 dB
- Setup: trace Offset down 1 dB

Util:

F3 Util: Autoset delay
<Ctrl> F3 Util: Autoset delay; sets to ± 70 ms
<Ctrl> Page Up Util: Zoom (Next)
<Ctrl> Page Dn. Util: Zoom (Previous)
<Shift> > Util: Smooth (Next)
<Shift> < Util: Smooth (Previous)
<Shift> F1/F2 Util: Gain A Up/Down 10 dB
<Shift> F3/F4 Util: Gain B Up/Down 10 dB
<Shift> F5/F6 Util: Gain C Up/Down 10 dB

Averages:

R Averaging Restart
Space Bar Disable/enable input toggle

Generator:

F1 Generator: Off

Cursor:

L/R arrow keys Moves cursor 1 bin L or R, disables peak track
<Ctrl> L/R Moves cursor 24 bins L or R, disables peak track
Up/Dn. arrow keys Moves cursor to next/previous trace
<Alt> P Cursor Peak track

v. 2.3 Stereo, v. 2.3 Multi-channel

Branch:

<Alt> + or N Branch (Next)
<Alt> - Branch (Previous)

Data:

F5 Freeze Frequency response trace and place in memory buffer
F6 Data: Clear
F10 Hides Live or Memory Traces (Toggle)

Setup:

= or + Setup: trace Offset up 1 dB
- Setup: trace Offset down 1 dB

Util:

F3 Util: Autoset branch delay
<Ctrl> F3 Util: Autoset branch delay; sets to ± 70 ms
<Ctrl> Page Up Util: Zoom (Next)
<Ctrl> Page Dn. Util: Zoom (Previous)
<Shift> > Util: Smooth (Next)
<Shift> < Util: Smooth (Previous)
<Shift> F1/F2 Util: Master gain Up/Down 10 dB
<Shift> F5/F6 Util: Position (Mic Gain) Up/Down 10 dB

Averages:

R Averaging Restart
Space Bar Disable/enable input toggle

Generator:

F1 Generator: Off

Cursor:

L/R arrow keys Moves cursor 1 bin L or R, disables peak track
<Ctrl> L/R Moves cursor 24 bins L or R, disables peak track
Up/Dn. arrow keys Moves cursor to next/previous trace
<Alt> P Resume peak track

**Sound
engineering
for the art
and science
of sound.**



**Meyer Sound Laboratories, Inc.
2832 San Pablo Avenue
Berkeley, CA 94702
(510) 486-1166
FAX (510) 486-8356**
