

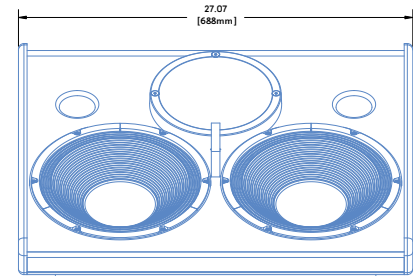

# MJF-212 : High-Power Stage Monitor

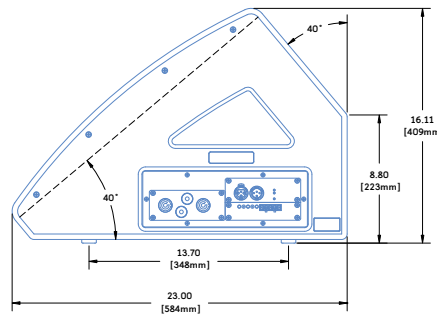

<b>Dimensions</b>	27.07" w x 16.11" h x 23.00" d (688 mm x 409 mm x 584 mm)
<b>Weight</b>	108 lbs (49 kg)
<b>Enclosure</b>	Premium birch plywood
<b>Finish</b>	Black textured
<b>Protective Grille</b>	Powder-coated hex-stamped steel, black mesh screen
<b>Audio Input</b>	Female XLR input with male XLR loop output or VEAM all-in-one connector
<b>AC Power Connector</b>	PowerCon® with looping output or VEAM all-in-one connector



The Meyer Sound MJF-212 is a self-powered stage monitor loudspeaker designed to meet critical requirements in professional applications. Exhibiting flat amplitude and phase responses, full-range bandwidth, and exceptional impulse response, the MJF-212 far exceeds the capabilities of conventional stage monitors while offering the simplicity of setup and operation provided by self-powered systems.

The MJF-212 monitor's phase-corrected frequency range of 55 Hz to 18 kHz enables accurate reproduction of both vocals and instruments with high gain before feedback, and provides excellent intelligibility at high output levels with low distortion and no coloration added to the signal. The face of the low-profile cabinet slopes at 40 degrees from the stage to permit optimal

placement relative to the talent, while its medium-Q horn provides even coverage in both the horizontal and vertical planes.

The loudspeaker's high-frequency section comprises a 4-inch diaphragm compression driver coupled to a symmetrical (50 degrees horizontal by 50 degrees vertical) constant directivity horn. A pair of high-power 12-inch neodymium magnet cone drivers with 4-inch voice coils, mounted in an optimally vented enclosure, reproduces low frequencies.

Each driver is powered by one channel of a three-channel class AB/H amplifier that employs complementary power MOSFET output stages to provide total burst output of 1275 watts (2 x 500 watts, 1 x 275 watts), 2550 watts peak. The MJF-212

incorporates Meyer Sound's Intelligent AC™ system for automatic voltage selection, EMI filtering, soft current turn-on, and surge suppression.

The cabinet is constructed from premium birch plywood and coated with a durable, textured black finish. A metal grille lined with acoustical black mesh protects the drivers. The rugged MJF-212 includes plastic skids on the bottom of the unit to prevent damage to the enclosure or stage floor.

The MJF-212 can be integrated into Meyer Sound's RMS™ remote monitoring system with the addition of an optional module. RMS is a Windows-based computer application for monitoring the full range of amplifier and limiter operating parameters.

## FEATURES & BENEFITS

- High peak power ensures excellent transient response
- Flat frequency and phase responses afford high levels of gain before feedback
- Low profile preserves sightlines
- Symmetrical, medium-Q pattern provides even coverage

## APPLICATIONS

- Main vocal monitor
- High-output drum or keyboard monitor
- Sidefill monitor for small- to medium-scale applications

# MJF-212 SPECIFICATIONS

<b>ACOUSTICAL</b>		<b>Operating Frequency Range</b> <sup>1</sup> 55 Hz – 18 kHz <b>Frequency Response</b> <sup>2</sup> 60 Hz – 16 kHz ±4 dB <b>Phase Response</b> 500 Hz – 16 kHz ±45° <b>Maximum Peak SPL</b> <sup>3</sup> 139 dB <b>Dynamic Range</b> >110 dB
<b>COVERAGE</b>		50° symmetrical
<b>CROSSOVER</b> <sup>4</sup>		1000 Hz
<b>TRANSDUCERS</b>		<b>Low Frequency</b> Two high-power 12" cone drivers with neodymium magnets Nominal impedance: 4 Ω Voice coil size: 4" Power handling capability: 1200 W (AES) <sup>5</sup> <b>High Frequency</b> 4" compression driver Nominal impedance: 8 Ω Voice coil size: 4" Diaphragm size: 4" Exit size: 1.5" Power handling capability: 250 W (AES) <sup>5</sup>
<b>AUDIO INPUT</b>		<b>Type</b> Differential, electronically balanced <b>Maximum Common Mode Range</b> ±15 V DC, clamped to earth for voltage transient protection <b>Connectors</b> Female XLR input with male XLR loop output or VEAM all-in-one connector (integrates AC, audio, and network) <b>Input Impedance</b> 10 kΩ differential between pins 2 and 3 <b>Wiring</b> Pin 1: Chassis/earth through 220 kΩ, 1000 pF, 15 V clamp network to provide virtual ground lift at audio frequencies Pin 2: Signal + Pin 3: Signal – Case: Earth ground and chassis <b>DC Blocking</b> Differential DC blocking up to max common mode voltage <b>CMRR</b> >50 dB, typically 80 dB (50 Hz–500 Hz) <b>RF Filter</b> Common mode: 425 kHz; Differential mode: 142 kHz <b>TIM Filter</b> Integral to signal processing (<80 kHz) <b>Nominal Input Sensitivity</b> 0 dBV (1 V rms, 1.4 V pk) continuous is typically the onset of limiting for noise and music <b>Input Level</b> Audio source must be capable of producing +20 dBV (10 V rms, 14 V pk) into 600 Ω in order to produce maximum peak SPL over the operating bandwidth of the loudspeaker
<b>AMPLIFIER</b>		<b>Type</b> Three-channel complementary MOSFET output stages (class AB/H) <b>Output Power</b> <sup>6</sup> 1275 W (three channels; 2 x 500 W, 1 x 275 W) <b>Total Output</b> <sup>7</sup> 2550 W peak <b>THD, IM, TIM</b> <.02% <b>Load Capacity</b> 4 Ω low channels; 8 Ω high channel <b>Cooling</b> Convection
<b>AC POWER</b>		<b>Connector</b> PowerCon with looping output or VEAM <b>Voltage Selection</b> Automatic, two ranges, each with high-low voltage tap (uninterrupted) <b>Safety Agency Rated Operating Range</b> 95 V AC – 125 V AC; 208 V AC – 235 V AC, 50/60 Hz <b>Turn-on and Turn-off Points</b> 85 V AC – 134 V AC; 165 V AC – 264 V AC <b>Current Draw: Idle Current</b> .680 A rms (115 V AC); .360 A rms (230 V AC); .760 A rms (100 V AC) <b>Max Long-Term Continuous Current (&gt;10 sec)</b> 4 A rms (115 V AC); 2 A rms (230 V AC); 4.6 A rms (100 V AC) <b>Burst Current (&lt;1 sec)</b> <sup>8</sup> 5 A rms (115 V AC), 2.5 A rms (230 V AC), 5.75 A rms (100 V AC) <b>Ultimate Short-Term Peak Current Draw</b> 13 A pk (115 V AC), 6.5 A pk (230 V AC), 15 A pk (100 V AC) <b>Inrush Current</b> 10 A pk (115 and 100 V AC), 18 A pk (230 V AC)
<b>RMS NETWORK (OPTIONAL)</b>		Equipped with two-conductor twisted-pair network, reporting all operating parameters of amplifiers to system operator's host computer

**NOTES:**

1. Recommended maximum operating frequency range. Response depends on loading conditions and room acoustics.
2. Half-space loading measured with 1/3-octave frequency resolution at 4 meters.
3. Measured with music, half-space loading, referred to 1 meter.
4. At this frequency, the transducers produce equal sound pressure levels.
5. Power handling is measured under AES standard conditions: transducers driven continuously for two hours with band limited noise signal having a 6 dB peak-average ratio.
6. Amplifier wattage rating based on the maximum unclipped burst sine-wave rms voltage that the amplifier will produce for at least 0.5 seconds into the nominal load impedance: 45 V rms low channels and 47 V rms high channel.
7. Peak power based on the maximum unclipped peak voltage that the amplifier will produce for at least 100 milliseconds into the nominal load impedance: 63 V peak low channels and 67 V peak high channel.
8. AC power cabling must be of sufficient gauge so that under burst current rms conditions, cable transmission losses do not drop voltage below specified operating range at the speaker.

Made by Meyer Sound Laboratories  
 Berkeley, California USA  
 European Office:  
 Meyer Sound Lab. GmbH  
 Carl Zeiss Strasse 13  
 56751 Polch, Germany



MJF-212 - 04.157.004.01 A

Copyright © 2006  
 Meyer Sound Laboratories Inc.  
 All rights reserved

**MEYER SOUND LABORATORIES INC.**  
 2832 San Pablo Avenue  
 Berkeley, CA 94702

T: +1 510 486.1166  
 F: +1 510 486.8356

techsupport@meyersound.com  
 www.meyersound.com

# ARCHITECT SPECIFICATIONS

The loudspeaker shall be a self-powered stage monitor; the transducers shall consist of two 12-inch diameter cone drivers and a 4-inch diaphragm compression driver on a 50-degree symmetrical horn. The loudspeaker system shall incorporate internal processing electronics and a three-channel amplifier, one channel for each driver. Processing functions shall include equalization, phase correction, signal division, and protection for the high- and low-frequency sections. The crossover point shall be 1000 Hz.

Each amplifier channel shall be class AB/H with complementary MOSFET output stages. Burst capability for the low-frequency channels shall be 500 watts total with nominal 4-ohm resistive load and 275 watts for the high-frequency channel with nominal 8-ohm resistive load. Peak power shall be 2550 watts. Distortion (THD, IM, TIM) shall not exceed 0.02%.

Performance specifications for a typical production unit shall be as follows, measured at 1/3-octave resolution: Operating frequency range shall be 55 Hz to 18 kHz. Phase response shall be ±45° from 500 Hz to 16 kHz. Maximum peak SPL shall be 139 dB at 1 meter, half-space loading. Coverage shall be 50 degrees by 50 degrees.

The audio input shall be electronically balanced with a 10 kOhm impedance and accept a nominal 0 dBV (1 V rms, 1.4 V pk) signal. Connector shall be XLR (A-3) type female with parallel looping Male or VEAM all-in-one multipin connector. RF filtering shall be provided, and CMRR shall be greater than 80 dB from 50 Hz to 500 Hz. The internal power supply shall perform automatic voltage selection, EMI filtering, soft current turn-on and surge suppression. Powering requirements shall be nominal 100, 110 or 230 V AC line current at 50 or 60 Hz. UL and CE operating voltage range shall be 100 to 240 V AC. Maximum peak current

draw during burst shall be 5 A at 115 V AC, 2.5 A at 230 V AC and 5.75 A at 100 V AC. Current inrush during soft turn-on shall not exceed 10 A at 115 V AC. AC power connectors shall be PowerCon with looping capabilities or VEAM all-in-one multipin connector.

The loudspeaker system shall provide facilities for installing Meyer Sound's optional RMS remote monitoring system. All components shall be mounted in an acoustically vented wedge-shaped enclosure constructed of premium birch plywood with a black textured hard-shell finish. The front grille shall be hex stamped steel with black mesh screen. Dimensions shall be 27.07" wide x 16.11" high x 23.00" deep (688 mm x 409 mm x 584 mm). Weight shall be 108 lbs (49 kg). The enclosure front angle shall be 40 degrees.

The loudspeakers shall be the Meyer Sound MJF-212