

UM-1P & 100P Q&A

The Meyer Sound Ultra Series™ UM-P Series monitors are powered systems that combine exceptionally accurate reproduction with high SPL output in very compact wedge enclosures. The UM-P Series features a uniquely robust built-in power biampifier that incorporates the electronic crossover, driver protection, and optimized pole-zero response correction circuitry.

The UM-P Series comprises two models, each utilizing a proprietary 12-inch cone low-frequency driver and a horn loaded 3-inch diaphragm high-frequency compression driver in a vented cabinet with carrying handles. The UM-1P affords a narrow 45° H x 45° V high-frequency coverage angle. The UM-100P provides a 100° H x 40° V coverage angle. Both horns feature true constant-Q high frequency directivity providing rapid attenuation outside of the coverage angle and minimal side lobes. The UM-1P and UM-100P were developed in Meyer Sound's anechoic test chamber by measuring coverage patterns using 1° angular resolution at 1/36 of an octave. Typically, both monitors provide 135 dB SPL in half space boundary conditions with a + 4dB amplitude response and + 35° phase response from 60Hz to 16 kHz.



UM-1P

UM-100P

PATENT PENDING

WHAT ARE THE INTENDED APPLICATIONS FOR THE UM-P SERIES SPEAKERS?

The UM-1P and UM-100P are high power low distortion monitors optimized to be positioned on the floor or other half space boundary condition. The UM-P Series is ideal for stage monitoring applications such as reproduction of musical instruments, singing and speech.

WHAT IS THE DIFFERENCE BETWEEN THE UM-1P AND THE UM-100P?

The UM-1P features a 45°H x 45° V horn making it ideal for applications where a narrow coverage pattern is required. The UM-100P features wider horizontal coverage with a 100° H x 40° V horn.

WHAT KIND OF POWER AMPLIFIER DOES THE UM-P SERIES USE?

The UM-P Series built-in electronics package features a new power biampifier designed specifically for the Powered UltraSeries™ products. The powerful, lightweight amplifier adds only 10 pounds to the weight of the cabinet while supplying 350 watts per channel of burst capability. The electronics virtually eliminate ground loop problems at the input by employing a differential receiver with high common mode rejection. A path to ground for RF and Electrostatic discharge provides full EMI protection.

WHAT ARE THE POWER REQUIREMENTS FOR THE UM-P SERIES SPEAKERS?

The UM-P Series requires a three conductor (hot, neutral, earth) AC input. It's electronics package incorporates Meyer Sound's exclusive Intelligent AC(circuitry which automatically adjusts for input mains voltages over the range of 80-264 VAC. Its AC current requirements for various nominal mains voltages and operating conditions are shown in figure 1.

Intelligent AC affords the UM-P Series significant benefits including international voltage compatibility and protection from voltage surges, faults and brownouts. In situations where power is supplied from a delta-wye source, the electrician may pick up any two available legs (hot-neutral or hot-hot) to supply the unit and be assured that it will work properly. In addition, Intelligent AC suppresses high-voltage transients and provides a soft-start function to eliminate high inrush currents on power-up.



**Meyer
Sound**

UM-1P & 100P *Q&A continued*



IS A SUBWOOFER REQUIRED WHEN USING THE UM-P SERIES?

No, when placed on a floor (half space loading condition) the UM-P Series has a response down to 60 Hz which is more than adequate for voice applications and most lead instruments. When using the UM-P to monitor full range music or musical instruments with significant sub-harmonic energy (below 60 Hz), such as drums or bass guitar, the UM-P can be supplemented with a USW-1P or other Meyer subwoofer.

WHAT ARE THE DIFFERENCES BETWEEN THE UM-1P AND THE UM-1?

The UM-P implements several design improvements. The amplifier is optimized for the system, providing substantial power without endangering the drivers. This optimization extends the durability and reliability of the loudspeaker. In addition, the integrated design simplifies set-up and installation, eliminating the need for amplifier racks. The UM-P also features a modular user panel which can be configured with the Remote Monitoring System (RMS) and any of three audio input modules.

WHAT IS RMS AND HOW IS IT BENEFICIAL FOR MONITORING APPLICATIONS?

Remote Monitoring System is a network system designed to interface with a Windows based PC. Each RMS enabled speaker returns data on signal and power levels, driver and cooling fan status, limiter activity, the position of the input polarity switch, the attenuator level, and amplifier temperature. The data for each speaker is displayed on the RMS host computer in an intuitive and configurable graphical representation of the speaker system. All RMS configured speakers can be installed on the same network, making RMS an ideal tool for eliminating all guesswork in troubleshooting problems during a performance and giving the monitor mixer an accurate picture of the conditions on stage even when mixing monitors from a remote location. See figure 2 for an RMS sample screen shot.

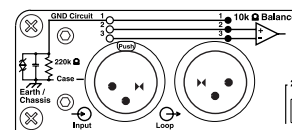

Standard Looping Module

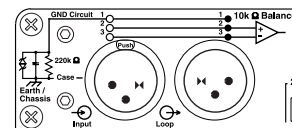

VC/Polarity Module

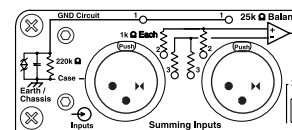

Summing Module

FIGURE 1

UM-P Current Ratings			
	115 V	230 V	100 V
Idle RMS	0.25 A _{RMS}	0.13 A _{RMS}	0.3 A _{RMS}
Max. Continuous RMS	2.8 A _{RMS}	1.4 A _{RMS}	3.2 A _{RMS}
Max. Burst RMS	3.2 A _{RMS}	1.6 A _{RMS}	3.7 A _{RMS}
Max. Peak During Burst	5.0 A _{PEAK}	2.5 A _{PEAK}	5.8 A _{PEAK}



**Meyer
Sound**

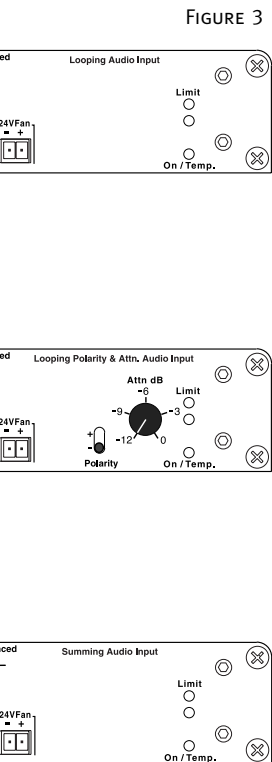

FIGURE 3

WHAT ARE THE AUDIO INPUT MODULE OPTIONS FOR THE UM-P SERIES?

There are three interchangeable audio input modules: the standard Looping Audio Input Module, the Summing Audio Input Module, and the Looping, Polarity, and Attenuating Audio Input Module. Refer to figure 3 for drawings of each audio input module.

The Looping Audio Input Module is the default audio input module. It uses a balanced, female XLR connector for audio input and a male XLR loop connector to interconnect or “daisy-chain” multiple speakers using a single audio signal. This audio input module is hardwired “pin-2 hot” meaning that a positive voltage on pin 2 relative to pin 3 will produce a positive pressure wave at the front of the speaker.

The Summing Audio Input Module uses two balanced female XLR connectors. Applying a signal to one of the inputs results in a normal signal level. Applying a signal to both inputs results in a correctly summed mono signal with each input 6dB below the level of a single input. This is an effective method for distributing both sides of a stereo signal to a single UM-P without requiring external level control.

The Looping, Polarity, and Attenuating Audio Input Module has a balanced female XLR audio input connector and a male XLR loop connector like the Looping Audio Input Module, but also features an input polarity switch and a level attenuator knob which operates between 0dB and -12 dB.

HOW MANY MONITORS CAN BE DAISY-CHAINED TOGETHER?

The input impedance of a single UM-P is 10 kΩ. The maximum number of UM-Ps that can be daisy chained together is dependent on total load impedance of the signal loop. For example, cascading 20 UM-Ps produces a balanced input load of 500Ω. If a 150Ω source is used, then the 500Ω load results in a 2.28dB loss. If you intend to loop more than 20 UM-Ps make sure that the source equipment is capable of driving the total impedance load created by the circuit.

FIGURE 2 RMS

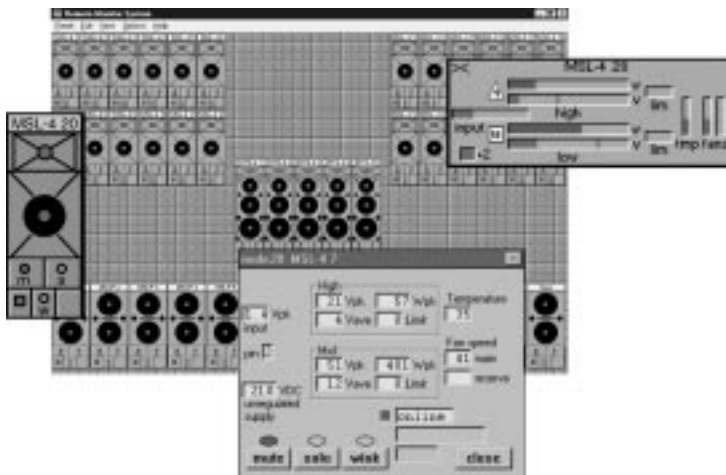

CAN THE UM-P BE RIGGED?

No, the UM-P is primarily designed as a floor monitor and has no rigging. It is specifically optimized for half-space loading. For applications where a cabinet must be flown, consider the Meyer UPA-P Series which can be configured with a variety of rigging options and is optimized for free field response.

CAN THE UM-P SERIES BE USED COMPATIBLY WITH THE OTHER PRODUCTS FROM THE SELF POWERED SERIES?

Yes, UM-P is fully compatible with all Meyer products. When using the UM-P with other Meyer products consult the Meyer Sound Technical Support department for optimal configuration ideas or use the Meyer SIM system-II to determine the proper delay times and equalization of each loudspeaker.

IS THE UM-P SERIES WEATHER RESISTANT?

Weather resistant versions of all Powered UltraSeries products are available; contact Meyer Sound for pricing and ordering details. Meyer Sound also offers an optional rain hood which protects the electronics and connectors from rain. Its use is strongly recommend in outdoor applications.

WHAT INTERNATIONAL SAFETY STANDARDS DOES THE UM-P SERIES SATISFY?

The UM-P Series complies with UL, C-UL, IEC 65, and effectively all international standards. In addition, it meets the requirements of the European Union's new EN 55103-1 and EN 55103-2 Electromagnetic Compatibility Emissions and Immunity standards for professional-use audio apparatus. These strict new EU standards cover a comprehensive range of disturbance phenomena, including RF electromagnetic fields, magnetic fields, power supply harmonic currents, AC port voltage fluctuations and inrush currents.

Meyer Sound Laboratories has devoted itself to designing, manufacturing, and refining components that deliver superb sonic reproduction. Every part of every component is designed and built to exacting specifications and undergoes rigorous, comprehensive testing in the laboratories.

Research remains an integral, driving force behind all production.

Meyer strives for sound quality that is predictable and neutral over an extended lifetime and across an extended range.

UM-1P/100P PHYSICAL DIMENSIONS

ALL UNITS IN INCHES

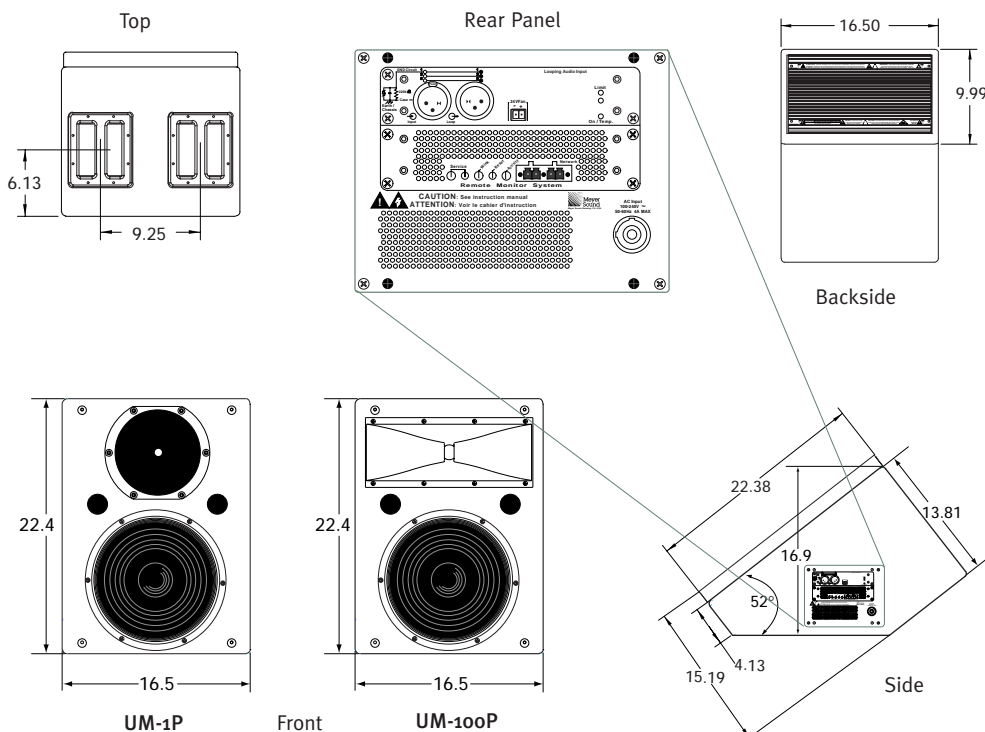

Specifications subject to change without notice



UM-1P/100P - 01.079.073.01

MEYER SOUND LABORATORIES, INC.
2832 San Pablo Avenue
Berkeley, CA 94702
tel: 510.486.1166
fax: 510.486.8356
e-mail: techsupport@meyersound.com
http: www.meyersound.com