

# Meyer Sound TechNotes™

## Two MSL-4s over Two DS-4Ps @ 30° Horizontal Splay

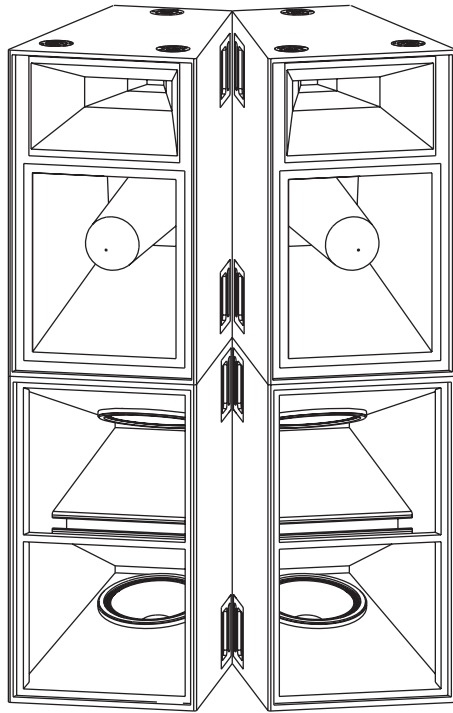

### ARRAY COVERAGE AND SPL COVERAGE:

Horizontal: 70°

Vertical: 35°

### MAXIMUM PEAK SPL @ 1 METER:

149 dB

### BASE SPECIFICATIONS FREQUENCY RANGE:

60 Hz to 18 kHz (1/2-space)<sup>1</sup>

### WEIGHT:

686 lbs. (311 kg)<sup>2</sup>

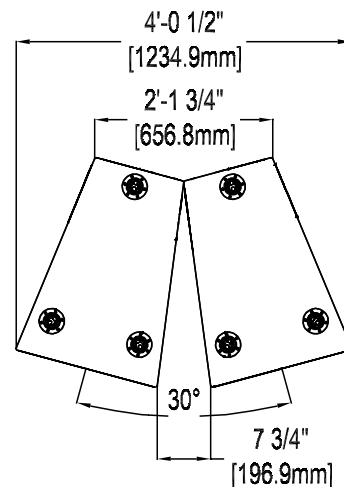

### MEASUREMENT NOTES

Frequency range constitutes the useable bandwidth after on-axis normalization with Meyer Sound CP-10 equalizer<sup>3</sup>. Coverage angles measured as the -6 dB (1/4 power) points from the normalized on-axis frequency response averaged over the 125 Hz to 8 kHz frequency band.

Maximum peak SPL measurements made under half-space conditions.

All measurements made at 4 meters in an anechoic chamber using Meyer Sound's high resolution loudspeaker measurement system at 1/36th-octave bands and confirmed at 8 meters in an outdoor area, under half-space conditions, with pink noise and measured at 1/24th-octave bands with a Meyer Sound SIM® II<sup>4</sup> measurement system.

1. free field
2. excluding rigging frames, motors and other hardware.
3. The Meyer Sound CP-10 is a dual-channel, complimentary phase, precision analog equalizer with five bands of parametric equalization and two bands of shelving filters.
4. The Meyer Sound SIM II is a computer-based dual-channel FFT analysis system optimized for electroacoustic measurements.

01.990.101.70 | 10.2000

Copyright © 2000 Meyer Sound Laboratories, Inc.  
All Rights Reserved

**MEYER SOUND LABORATORIES, INC.**

2832 SAN PABLO AVENUE  
BERKELEY, CALIFORNIA 94702

T: 510.486.1166 F: 510.486.8356

techsupport@meyersound.com  
www.meyersound.com

